

**Kehlnahtschleifer**  
**Fillet weld grinder**  
**Meuleuse pour soudures d'angle**

## UKC 3-R

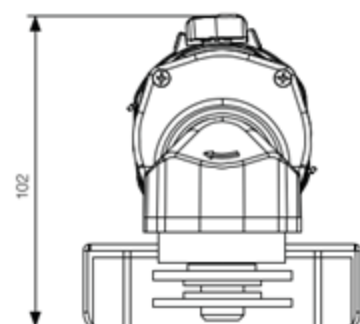

- Digital electronics with soft-start
- Specially developed for metal construction
- Overload protection and speed stabilisation
- Variable speed selector from 1 400 to 3 200 min<sup>-1</sup>
- Warning light when carbon brushes are worn: LED (at the back of the black case) lights up as soon as the carbon brushes need changing.

### Applications

Special grinder for processing difficult-to-access fillet welds.

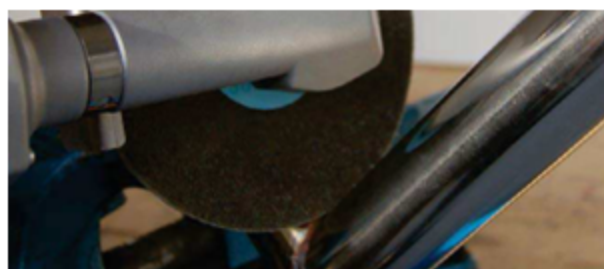

#### Technische Daten / Technical data / Caractéristiques techniques

Typ Type Type	Best.-Nr. Order No. No. de cde.	Drehzahl Speed Vitesse	Spannung Voltage Tension	max. Werkzeug max. wheel Outil max.	Gewicht Weight Poids
		min <sup>-1</sup>		ø	kg
UKC 3-R	111 301	1 400 – 3 200	230V/50Hz	150mm	1,950