



E-Flo® DC Motor

3A4801E
EN

Electric drive for low to medium volume paint circulation pumps.
For professional use only.



Important Safety Instructions

Read all warnings and instructions in this manual. Save these instructions.

See page 3 for model part numbers and approvals information.

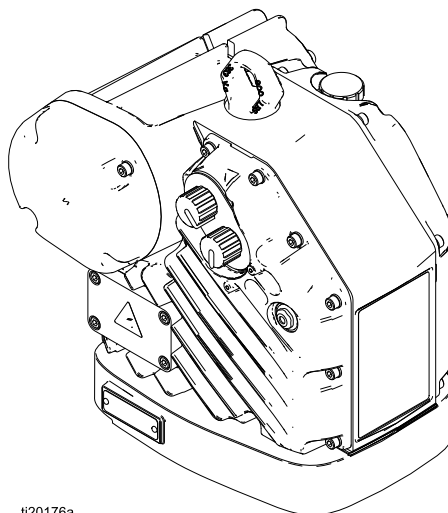

ti20176a

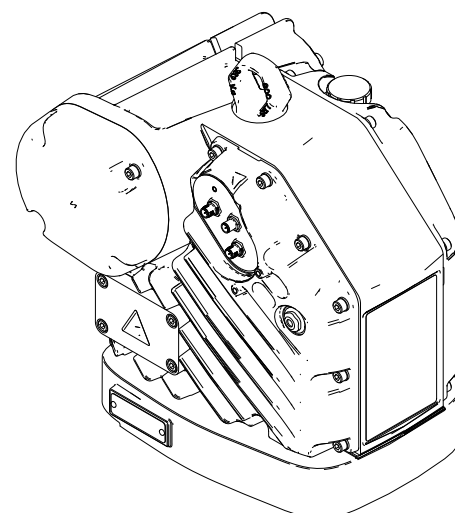

Contents

Related Manuals	2	Fan Coupler Replacement Kit 16J463	20
Models	3	Complete Fan Replacement Kit 26A395	22
Basic Models	3	Gear and Output Shaft Replacement Kits:	
Basic Models with Region-Specific		26A401 (series A/B), 26A398 (series	
Approvals	3	C), and 26A399	25
Advanced Models	4	Rotor Replacement Kit 26A397	30
Advanced Models with Region-Specific		Control Board Replacement Kits 24U934,	
Approvals	4	24U936, 24U935, 24U937	34
Warnings	5	Encoder Replacement Kit 24U938	36
Parts — Gear Box	8	Position Sensor Replacement Kit 24W920	39
Parts — Electrical Enclosure	10	Advanced Power Board Replacement Kit	
Repair Kits and Accessories	13	24U939	41
Prepare for Repair	15	Technical Specifications	44
Installation	16	Notes	45
Output Shaft Bearing Replacement	18		
Fan Only Replacement Kit 26A396	19		

Related Manuals

Manual Number	Title
3A2526	E-Flo DC Motor , Single Phase; Instructions-Installation
3A4409	E-Flo DC Motor, Three Phase; Instructions-Installation
3A2527	E-Flo DC Control Module Kit; Instructions-Parts

Models

Basic Models

Motor Part No.	Series	Horsepower	Maximum Force, lbf (N)
EM0011	C	1	1400 (6227)
EM0021	C	2	2800 (12455)
EM1011	A	1	1400 (6227)
EM1021	A	2	3500 (15570)

See installation and instruction manual for product approvals.

Basic Models with Region-Specific Approvals

Motor Part No.	Series	Horsepower	Maximum Force, lbf (N)
EM0013	C	1	1400 (6227)
EM0023	C	2	2800 (12455)
EM1013	A	1	1400 (6227)
EM1023	A	2	3500 (15570)

See installation and instruction manual for product approvals.

Specific Conditions of Use

1. Consult the manufacturer if dimensional information on the flameproof joint is necessary.
2. Consult the manufacturer for genuine replacement fasteners. M8 x 30 socket-head cap screws of Class 12.9 steel or better with a minimum yield strength of 1100 MPa (160,000 psi) are acceptable alternatives.

Advanced Models

Motor Part No.	Series	Horsepower	Maximum Force, lbf (N)
EM0012	C	1	1400 (6227)
EM0015	C	1	1400 (6227)
EM0022	C	2	2800 (12455)
EM0025	C	2	2800 (12455)
EM1012	A	1	1400 (6227)
EM1015	A	1	1400 (6227)
EM1022	A	2	3500 (15570)
EM1025	A	2	3500 (15570)

See installation and instruction manual for product approvals.

Advanced Models with Region-Specific Approvals

Motor Part No.	Series	Horsepower	Maximum Force, lbf (N)
EM0014	C	1	1400 (6227)
EM0016	C	1	1400 (6227)
EM0024	C	2	2800 (12455)
EM0026	C	2	2800 (12455)
EM1014	A	1	1400 (6227)
EM1016	A	1	1400 (6227)
EM1024	A	2	3500 (15570)
EM1026	A	2	3500 (15570)







See installation and instruction manual for product approvals.





Specific Conditions of Use

1. Consult the manufacturer if dimensional information on the flameproof joint is necessary.
2. Consult the manufacturer for genuine replacement fasteners. M8 x 30 socket-head cap screws of Class 12.9 steel or better with a minimum yield strength of 1100 MPa (160,000 psi) are acceptable alternatives.

Warnings

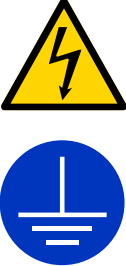





The following warnings are for the setup, use, grounding, maintenance, and repair of this equipment. The exclamation point symbol alerts you to a general warning and the hazard symbols refer to procedure-specific risks. When these symbols appear in the body of this manual or on warning labels, refer back to these warnings. Product-specific hazard symbols and warnings not covered in this section may appear throughout the body of this manual where applicable.

 WARNING	
    	<p>FIRE AND EXPLOSION HAZARD</p> <p>Flammable fumes, such as solvent and paint fumes, in the work area can ignite or explode. To help prevent fire and explosion:</p> <ul style="list-style-type: none"> • Use equipment only in well-ventilated areas. • Eliminate all ignition sources such as pilot lights, cigarettes, portable electric lamps, and plastic drop cloths (potential static sparking). • Ground all equipment in the work area. See the installation manual for Grounding instructions. • Keep work area free of debris, including solvent, rags and gasoline. • Do not plug or unplug power cords, or turn power or light switches on or off when flammable fumes are present. • Use only grounded hoses. • Hold gun firmly to side of grounded pail when triggering into pail. Do not use pail liners unless they are antistatic or conductive. • Stop operation immediately if static sparking occurs or you feel a shock. Do not use equipment until you identify and correct the problem. • Keep a working fire extinguisher in the work area. <p>Static charge may build up on plastic parts during cleaning and could discharge and ignite flammable vapors. To help prevent fire and explosion:</p> <ul style="list-style-type: none"> • Clean plastic parts only in well-ventilated area. • Do not clean with a dry cloth. • Do not operate electrostatic guns in equipment work area.
	<p>SPECIAL CONDITIONS FOR SAFE USE</p> <ul style="list-style-type: none"> • To prevent the risk of electrostatic sparking, the equipment's non-metallic parts should be cleaned only with a damp cloth. • The aluminum housing may spark upon impact or contact with moving parts, which may cause fire or explosion. Take precautions to avoid such impact or contact. • All flameproof joints are critical to the integrity of the motor as approved for hazardous locations and are not repairable if damaged. Damaged parts must be replaced only with genuine Graco parts with no substitutions.

 <h1 style="margin: 0;">WARNING</h1>	
	<p>ELECTRIC SHOCK HAZARD</p> <p>This equipment must be grounded. Improper grounding, setup, or usage of the system can cause electric shock.</p> <ul style="list-style-type: none"> • Turn off and disconnect power at main switch before disconnecting any cables and before servicing or installing equipment. • Connect only to grounded power source. • All electrical wiring must be done by a qualified electrician and comply with all local codes and regulations.
	<p>INTRINSIC SAFETY</p> <p>Intrinsically safe equipment that is installed improperly or connected to non-intrinsically safe equipment will create a hazardous condition and can cause fire, explosion, or electric shock. Follow local regulations and the following safety requirements.</p> <ul style="list-style-type: none"> • Be sure your installation complies with national, state, and local codes for the installation of electrical apparatus in a Class I, Group D, Division 1 Hazardous Location, including all of the local safety fire codes, NFPA 33, NEC 500 and 516, and OSHA 1910.107. • Equipment that comes in contact with the equipment's intrinsically safe terminals must meet the entity parameter requirements specified in Control Drawing 24N637. See the installation manual for instructions for Intrinsically Safe Installation Requirements for Advanced Motors. This includes safety barriers, DC voltage meters, ohmmeters, cables, and connections. Remove the unit from the hazardous area when troubleshooting. • Do not install any equipment approved only for a non-hazardous location in a hazardous area, as defined in Article 500 of the National Electrical Code (USA) or your local electrical code. See the ID label for the intrinsic safety rating for your equipment. • Ground the motor. Use a 12 gauge minimum ground wire, connected to a true earth ground. See the installation manual for Grounding instructions. • Do not operate the motor with any cover removed. • Do not substitute system components, as this may impair intrinsic safety.
	<p>BURN HAZARD</p> <p>Equipment surfaces and fluid that is heated can become very hot during operation. To avoid severe burns:</p> <ul style="list-style-type: none"> • Do not touch hot fluid or equipment.
	<p>MOVING PARTS HAZARD</p> <p>Moving parts can pinch, cut, or amputate fingers and other body parts.</p> <ul style="list-style-type: none"> • Keep clear of moving parts. • Do not operate equipment with protective guards or covers removed. • Pressurized equipment can start without warning. Before checking, moving, or servicing equipment, follow the Pressure Relief Procedure and disconnect all power sources.



WARNING

 	<p>PRESSURIZED EQUIPMENT HAZARD</p> <p>Fluid from the equipment, leaks, or ruptured components can splash in the eyes or on skin and cause serious injury.</p> <ul style="list-style-type: none"> • Follow the Pressure Relief Procedure when you stop spraying/dispensing and before cleaning, checking, or servicing equipment. • Tighten all fluid connections before operating the equipment. • Check hoses, tubes, and couplings daily. Replace worn or damaged parts immediately.
	<p>TOXIC FLUID OR FUMES HAZARD</p> <p>Toxic fluids or fumes can cause serious injury or death if splashed in the eyes or on skin, inhaled, or swallowed.</p> <ul style="list-style-type: none"> • Read Safety Data Sheets (SDSs) to know the specific hazards of the fluids you are using. • Store hazardous fluid in approved containers, and dispose of it according to applicable guidelines.
	<p>PERSONAL PROTECTIVE EQUIPMENT</p> <p>Wear appropriate protective equipment when in the work area to help prevent serious injury, including eye injury, hearing loss, inhalation of toxic fumes, and burns. This equipment includes but is not limited to:</p> <ul style="list-style-type: none"> • Protective eyewear, and hearing protection. • Respirators, protective clothing, and gloves as recommended by the fluid and solvent manufacturer.
 	<p>EQUIPMENT MISUSE HAZARD</p> <p>Misuse can cause death or serious injury.</p> <ul style="list-style-type: none"> • Do not operate the unit when fatigued or under the influence of drugs or alcohol. • Do not exceed the maximum working pressure or temperature rating of the lowest rated system component. See Technical Specifications in all equipment manuals. • Use fluids and solvents that are compatible with equipment wetted parts. See Technical Specifications in all equipment manuals. Read fluid and solvent manufacturer's warnings. For complete information about your material, request Safety Data Sheets (SDSs) from distributor or retailer. • Do not leave the work area while equipment is energized or under pressure. • Turn off all equipment and follow the Pressure Relief Procedure when equipment is not in use. • Check equipment daily. Repair or replace worn or damaged parts immediately with genuine manufacturer's replacement parts only. • Do not alter or modify equipment. Alterations or modifications may void agency approvals and create safety hazards. • Make sure all equipment is rated and approved for the environment in which you are using it. • Use equipment only for its intended purpose. Call your distributor for information. • Route hoses and cables away from traffic areas, sharp edges, moving parts, and hot surfaces. • Do not kink or over bend hoses or use hoses to pull equipment. • Keep children and animals away from work area. • Comply with all applicable safety regulations.

Parts — Gear Box

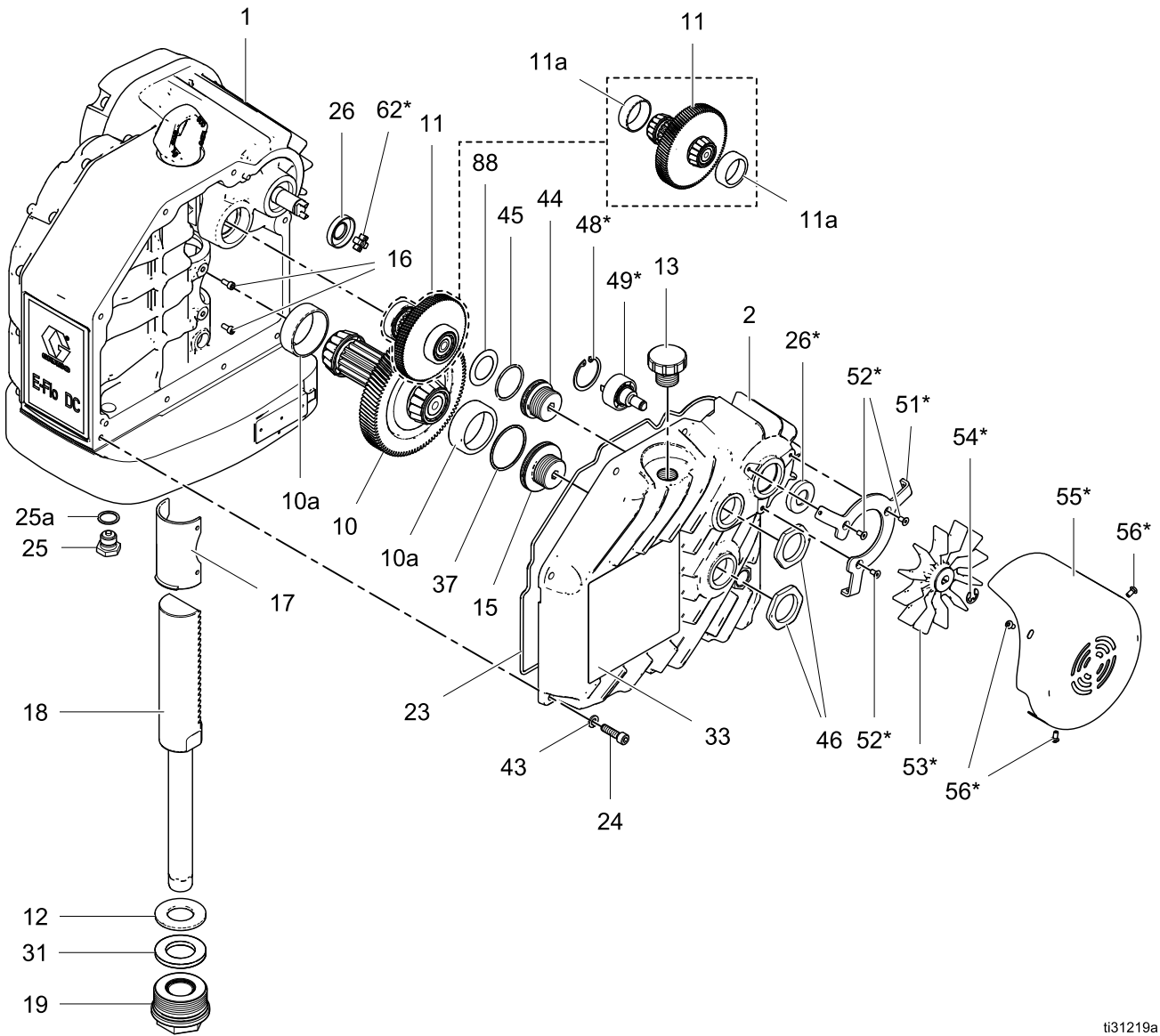

ti31219a

Ref No.	Part Number	Description	Qty
1	— — — —	Motor housing	1
2	— — — —	Gear cover	1
10 ⁺	— — — —	2nd stage gear assembly	1
10a ⁺	— — — —	2nd stage bearing	2
11 ^{+◇}	— — — —	1st stage gear assembly	1
11a ^{+◇}	— — — —	1st stage bearing	1
12 ^{«#}	— — — —	Support washer	1
13	15H525	Fill cap	1
15	— — — —	2nd stage bearing adjuster	1
16	— — — —	Socket head cap screw, M5–0.8 x 12 mm	2
17 [«]	— — — —	Rack bearing	1
18 [«]	— — — —	Output shaft assembly	1
19 ^{«#}	— — — —	Output shaft bearing assembly	1
23 ^{+◇}	16K443	Gear housing gasket	1
24 ⁼	— — — —	Socket head cap screw, M8–0.25 x 30 mm	8
25	15H432	Oil drain plug, with gasket	1
25a	17T713	Drain plug gasket	1
26 ^{+^}	15H493	Shaft seal	1
31 ^{«#}	— — — —	Lower bumper	1
33 [▲]	17J476	Safety warning label; models EM00X1, EM00X2, EM00X5	1
	16W360	Safety warning label; models EM00X3, EM00X4, EM00X6	1
37 ⁺	— — — —	O-ring packing	1
43 ⁼	— — — —	Lock washer	8
44 ⁺	— — — —	1st stage roller bearing adjuster	1

Ref No.	Part Number	Description	Qty
45 ⁺	— — — —	O-ring packing	1
46	— — — —	Jam nut	2
48 [*]	— — — —	Internal retaining ring (snap ring)	1
49 ^{*^}	— — — —	Fan bearing assembly	1
51 ^{*±}	— — — —	Fan cover bracket	1
52 ^{*±}	— — — —	Flat head screw, M5–0.8 x 10 mm	3
53 ^{*+^°}	— — — —	Fan motor	1
54 ^{*+^°}	— — — —	Retaining clip	1
55 ^{*±}	— — — —	Fan cover	1
56 ^{*±}	— — — —	Button head cap screw, stainless steel; M5–0.8 x 10 mm	3
62 ^{*^}	16J463	Backlash-free shaft coupler	1
88 ⁺	— — — —	Disc spring (Series A/B only)	1

* Included with 2 horsepower models only

+ Included in Gear Kits: 26A398 series A-B, 26A401 (series C+)

◇ Included in First Stage Gear Kit 26A569 series A-B

« Included in Output Shaft Kit 26A399

Included in Output Shaft Bearing Kit 26A442

± Included in Fan Cover Kit 26A539

^ Included in Complete Fan Kit 26A395

° Included in Fan Kit 26A396.

= Included in Bolt Kit 26A537

▲ Replacement danger and warning labels, signs, tags, and cards are available at no cost.

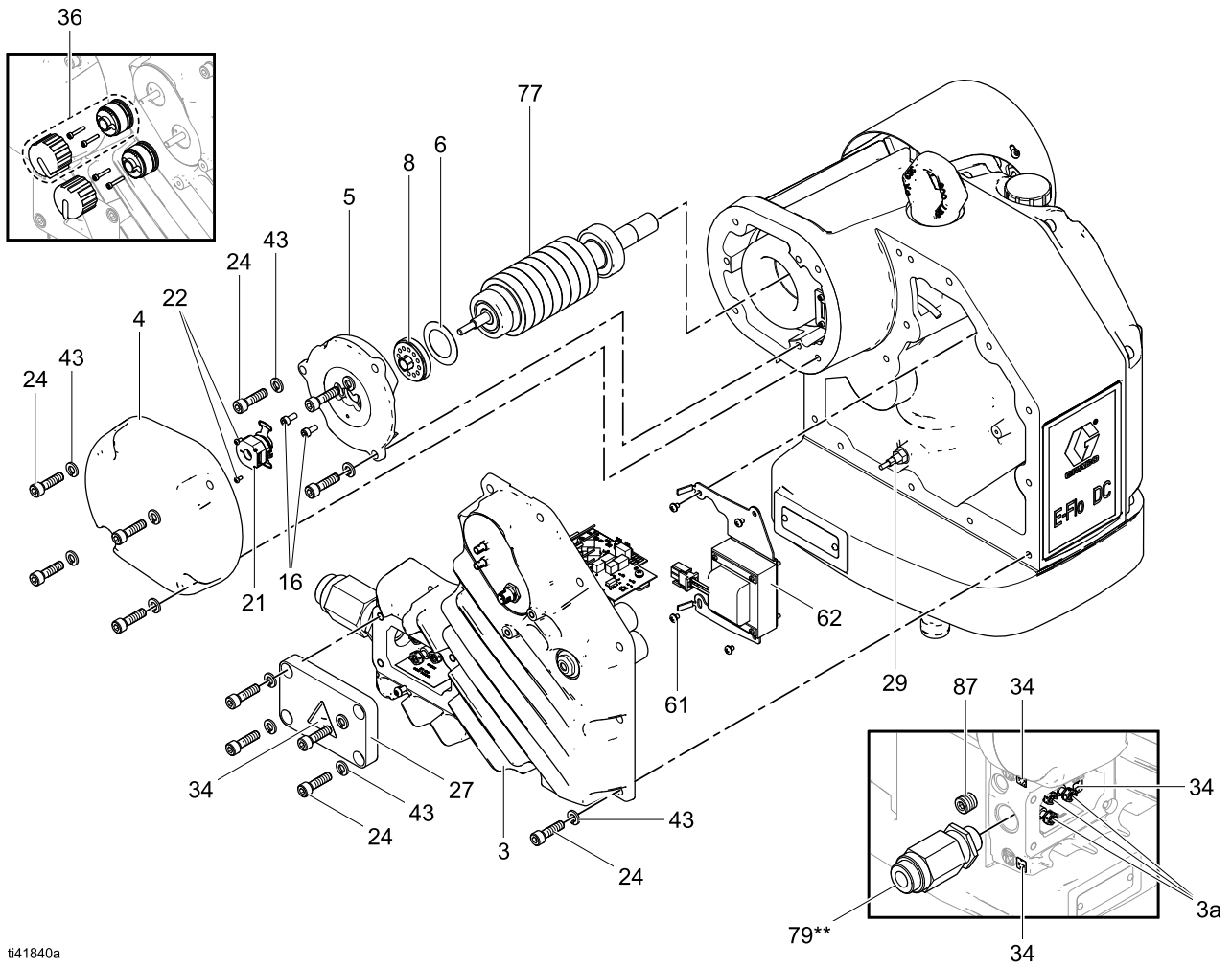

ti41840a

Figure 2 Three Phase Models

Parts — Electrical Enclosure

Ref No.	Part Number	Description	Qty
3#	— — —	Electronics cover	1
3a#	108675	Wiring post	2
4	— — —	Motor cover	1
5>	— — —	Rotor support	1
6>	— — —	Disc spring	1
8>	— — —	Rotor adjuster	1
16>	— — —	Socket head cap screw, M5-0.8 x 12 mm	2
21+	— — —	Encoder	1
22+	— — —	Cross recessed pan head machine screw, #4-40 x 0.25	2
24«	— — —	Socket head cap screw, M8-0.25 x 30 mm	23
27	26A538	Wiring cover	1
29^	— — —	Stroke position sensor	1
34▲	16T764	Warning labels; one sheet	1
36†	16U113	Knob replacement kit (basic models)	2
43«	— — —	Lock washer	23
57	— — —	Standoff spacer	4
58*°	— — —	Board assembly, 3mcp Is can barrier	1
59*	— — —	Socket head cap screw, M6-1 x 35 mm	2
60*	— — —	Power barrier board shield	1
61	— — —	Phillips screw, #8-32 x 0.25 (basic models)	2
		Phillips screw, #8-32 x 0.25 (advanced models)	4

Ref No.	Part Number	Description	Qty
62	— — —	Inductor assembly (three phase models)	1
69*°	— — —	Wiring tie strap; not shown	1
72	— — —	Motor wire bracket (basic models)	1
77>	— — —	Rotor	1
79	17D463	Flameproof cable gland (models EM00X3, EM00X4, EM00X6 only)	1
	19D420	Flameproof cable gland (models EM10X3, EM10X4, and EM10X6 only)	
87	17G761	Recessed hex socket plug, 3/8-18 NPT (Series C+ only)	1

* Parts included with advanced models only.

✦ Included with single phase models

† Included with basic models only

> Included in Rotor Kit 26A397

+ Included in Encoder Kit 24U938

« Included in Bolt Kit 26A537

^ Included in Sensor Kit 24W920

° Included in Power Board Kit 24U939

Included in Control Board Kit (See [Repair Kits and Accessories](#), page 13.)

▲ Replacement danger and warning labels, signs, tags, and cards are available at no cost.





Repair Kits and Accessories

Motor Part No.	Description	Kits	Kit Description
All motors in this manual	E-Flo DC Motors	26A398	Gear Kit, Series C and above
		26A401	Gear Kit, Series A, B
		26A569	First Stage Gear Kit, Series A, B
		26A399	Output Shaft Kit
		26A397	Rotor Kit
		26A442	Output Seal Kit
		16W645	ISO 220 Silicone-Free Synthetic Gear Oil; 1 quart (0.95 liter); order two
		24W920	Position Sensor Kit
		24U938	Encoder Kit
		26A537	Bolt Kit
Models EM00X1, EM00X3	E-Flo DC Basic Motors	16U113	Knob Kit (36) See Parts — Electrical Enclosure, page 10 . Includes replacement parts for one knob.
Model EM001X	E-Flo DC Basic Motors	24U934	Electric 1HP Control Board, EM001X
Model EM002X	E-Flo DC Basic Motors	24U936	Electric 2HP Control Board, EM002X
		26A395	Complete Fan Kit See Complete Fan Replacement Kit 26A395, page 22 .
		26A396	Fan Kit (fan and clip only) See Fan Only Replacement Kit 26A396, page 19 .
		16J463	Fan Coupler Kit See Fan Coupler Replacement Kit 16J463, page 20 .
		26A539	Fan Cover Kit
Models EM00X2, EM00X4, EM00X5, EM00X6	E-Flo DC Advanced Motors	16P911	CAN Cable, 3 ft (1 m)
		16P912	CAN Cable, 25 ft (8 m)
		16U729	Start/Stop Switch. Allows the pump to be shut off while maintaining power to the control module.
		24P822	Control Module, for Advanced Motors See the instruction manual for the DC Control Module Kit.
		24P979	Pneumatic Control for Back Pressure Regulator. See the instruction manual for Pneumatic Control.
		24R050	Pressure Transducer Kit
		24U935	Electric 1HP Control Board, EM001X
		24U937	Electric 2HP Control Board, EM002X.
		24U939	Powerboard

Repair Kits and Accessories

Motor Part No.	Description	Kits	Kit Description
All motors in this manual	Connection kits, to mount an E-Flo DC Motor to an existing pump lower. Kits include tie rods, tie rod nuts, adapter, and coupler.	288203	For 3000 and 4000 cc 4-Ball Lowers
		288204	For Dura-Flo 1800 and 2400 Lowers
		288205	For Dura-Flo 600, 750, 900, and 1200 Lowers
		288206	For Dura-Flo 1000 Lowers
		288207	For Xtreme 145, 180, 220, 250, and 290 Lowers
		288209	For 750, 1000, 1500, and 2000 cc 4-Ball Lowers with Enclosed or Open Wet Cup
		288860	For Xtreme 85 and 115 Lowers
	17K525	For 750, 1000, 1500, and 2000 cc Sealed 4-Ball Lowers	
	Mounting Bracket	255143	Wall Bracket See the instruction manual for the NXT Air Motor Mounting Conversion 312148.

Prepare for Repair





				
<p>To avoid electric shock, turn off the equipment power and shut off the power at the main circuit breaker before installing.</p>				

1. Remove power from the motor.
2. Follow the appropriate lock-out/tag-out procedures.
3. Follow the [Pressure Relief Procedure, page 15](#).
4. Decouple the pump lower from the motor.
5. If you are replacing the fan coupler, fan shaft, gear shaft, or output shaft, see [Drain the Oil, page 17](#).

Pressure Relief Procedure



Follow the Pressure Relief Procedure whenever you see this symbol.

				
<p>This equipment stays pressurized until pressure is manually relieved. To help prevent serious injury from splashing fluid and moving parts, follow the Pressure Relief Procedure when you stop spraying and before cleaning, checking, or servicing the equipment.</p>				

1. Disengage the start/stop control (C). See [Connect the Power Supply, page 16](#).
2. Shut off and lock out the fused safety switch (B).
3. Relieve all fluid pressure as explained in your separate E-Flo DC pump manual.

Installation

Connect the Power Supply

<p>Improper wiring may cause electric shock or other serious injury if work is not performed properly. Have a qualified electrician perform any electrical work. Be sure your installation complies with all local safety and fire codes.</p>				

1. Ensure that the fused safety switch (B) is shut off and locked out.

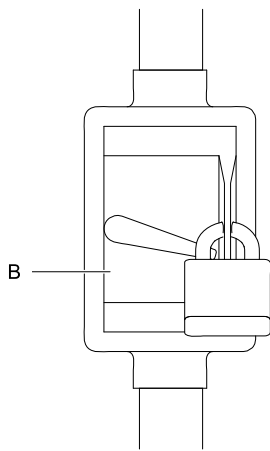

Figure 3 Locked Out Fused Safety Switch

2. Install a start/stop control (C) in the electrical supply line (A), within easy reach of the equipment. The start/stop control must be approved for use in hazardous locations.
3. Open the electrical compartment (S) on the motor.

4. Bring the power wires into the electrical compartment through the 3/4–14 npt(f) inlet port. Connect the wires to the terminals, as shown. Torque the terminal nuts to 15 in-lb (2 N•m) maximum. **Do not over-torque.**
5. Close the electrical compartment. Torque the cover screws (J) to 15 ft-lb (20 N•m).

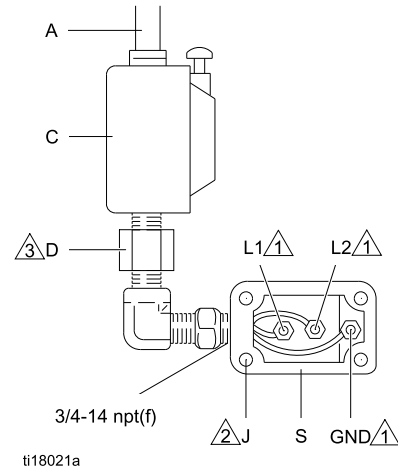

Figure 4 Connect the Power Wires

Notes	
	Tighten all terminal nuts to 15 in-lb (2 N•m) maximum. Do not over-torque.
	Tighten cover screws to 15 ft-lb (20 N•m).
	A conduit seal (D) is required within 18 in. (457 mm) of the motor for the US and Canada.

Change the Oil

NOTE: Change the oil after a break-in period of 200,000–300,000 cycles. After the break-in period, change the oil once a year. Order two of Part No. 16W645 ISO 220 silicone-free synthetic gear oil.

Drain the Oil

1. Place a minimum two-quart (1.9 liter) container under the oil drain port. Remove the oil drain plug (25). Allow all oil to drain from the motor.
2. Reinstall the oil drain plug (25). Torque to 25 ft-lb (34 N•m).

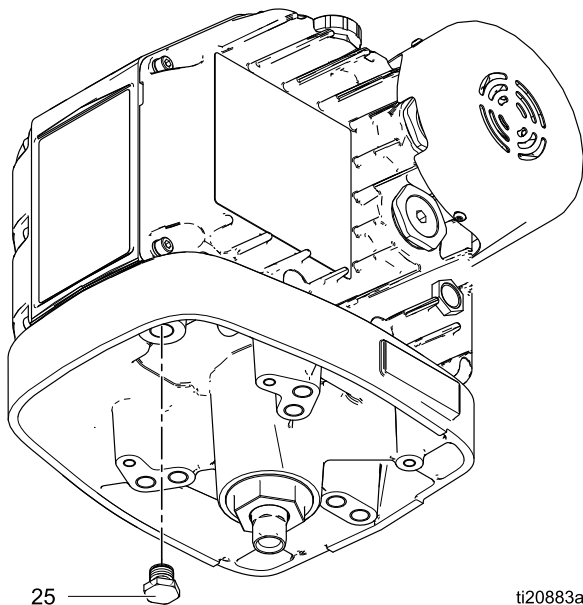

ti20883a

Figure 5 Oil Drain Plug

Fill the Oil

1. Open the fill cap (P) and add Graco Part No. 16W645 ISO 220 silicone-free synthetic gear oil. Check the oil level in the sight glass (K). Fill until the oil level is near the halfway point of the sight glass. The oil capacity is approximately 1.5 quarts (1.4 liters).
2. Reinstall the fill cap.

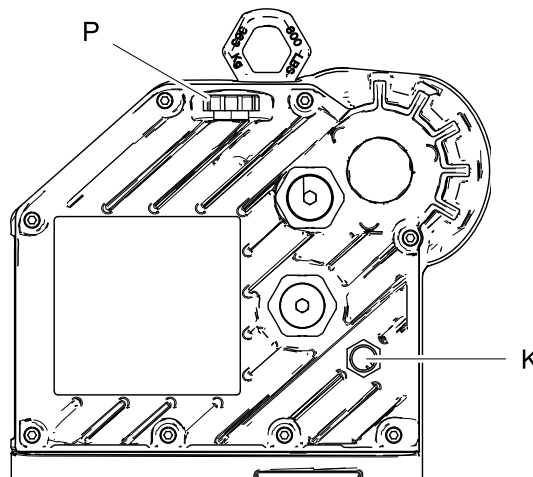

ti19679aFigure

6 Sight glass location

Output Shaft Bearing Replacement



Tools Required

- 2 inch hex wrench
- Torque wrench 23 ft-lb (31 N•m)
- Torque wrench 80 ft-lb (108 N•m)

Replace the Output Shaft Bearing

1. Stop the pump at the top of its stroke.
2. Follow the instructions in [Prepare for Repair, page 15](#).
3. Reinstall the oil drain plug (25). Torque to 25 ft-lb (34 N•m).
4. Unscrew and remove the output shaft bearing (19) from the motor. See [Parts — Gear Box, page 8](#).
5. Install the new bearing (19), bumper (31), and washer (12). Torque to 70 ft-lb (95 N•m).
6. Fill with oil. See [Fill the Oil, page 17](#).
7. Reconnect the lower to the motor.

Fan Only Replacement Kit 26A396

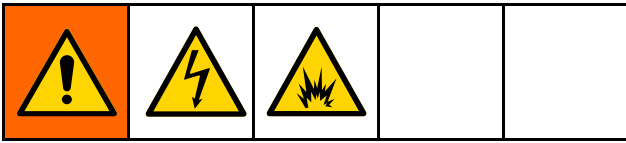

Tools Required

- 3 mm hex wrench
- Flathead screwdriver

Remove the Fan

1. Follow the instructions in [Prepare for Repair, page 15](#).
2. Using a 3 mm hex wrench, remove the three fan cover screws (56) and then remove the cover (55).

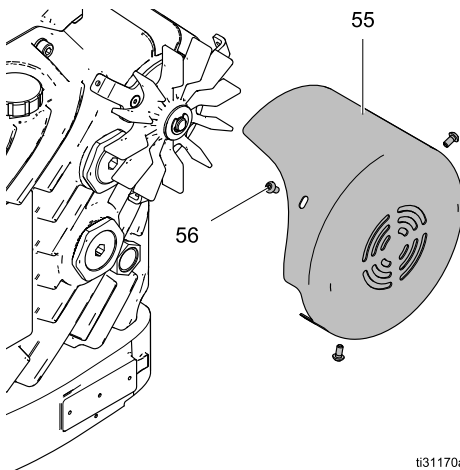

Fan Cover

55	Fan cover
56	Screws

3. Using a flathead screwdriver, remove the retaining clip (54).

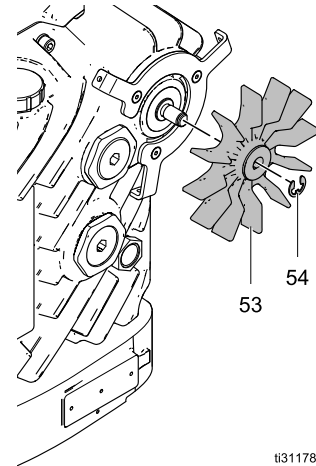

Fan

53	Fan
54	Retaining clip

4. Pull the fan (53) to remove it. It is a pressed-on fit. Be careful not to damage the seal (26).

Install the Fan

1. Press the fan (53) onto the fan shaft (49).
2. Attach the retaining clip (54) into the groove in the fan shaft, lining up the clearance flat of the shaft with the clip ends.
3. Using a 3 mm hex wrench, secure the fan cover (55) with the three screws (56).

Fan Coupler Replacement Kit 16J463

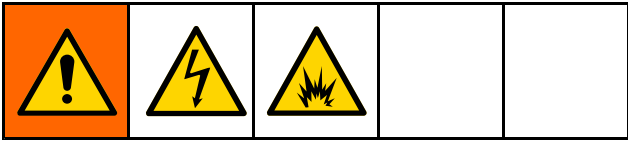

Tools Required

- 3 mm hex wrench
- 6 mm hex wrench
- Torque wrench 20 ft-lb (27 N•m)

Remove the Gear Cover

1. Follow the instructions in [Prepare for Repair, page 15](#).
2. Using a 3 mm hex wrench, remove the three fan cover screws (56) and then remove the cover (55).

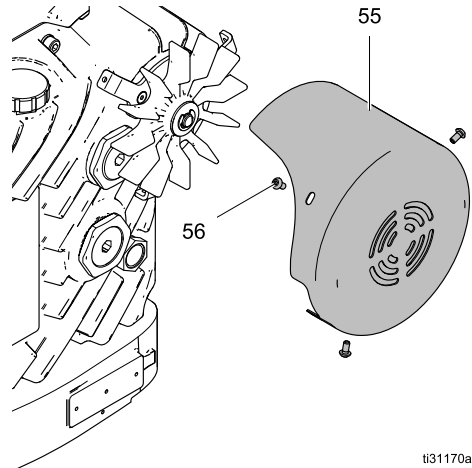

t31170a

Fan Cover

55	Fan cover
56	Screws

3. Remove the eight 6 mm hex screws (24) and washers (43) from the gear cover (2).
4. The gear cover is mounted on two dowels. Pull the cover straight out to remove it.

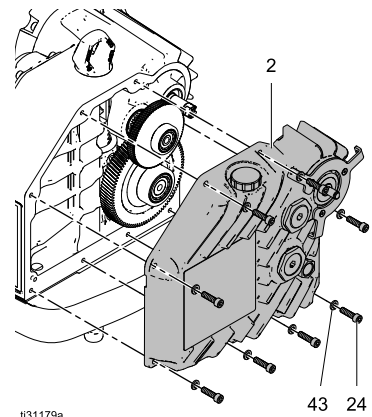

t31179a

Gear Cover

2	Gear cover
24	Hex screws
43	Washer

Replace the Fan Coupler

1. Remove the fan coupler (62) from the fan bearing assembly (49) in the gear cover.

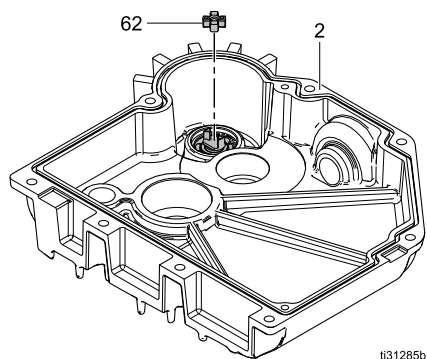

Fan Components

2	Gear cover
62	Fan coupler

2. Insert the new fan coupler.

Install the Gear Cover

1. Place the gear cover on the motor housing and secure it with the eight 6 mm hex screws (24) and washers (43). Torque to 15 ft-lb (20 N•m).

2. Using a 3 mm hex wrench, secure the fan cover (55) with the three screws (56).

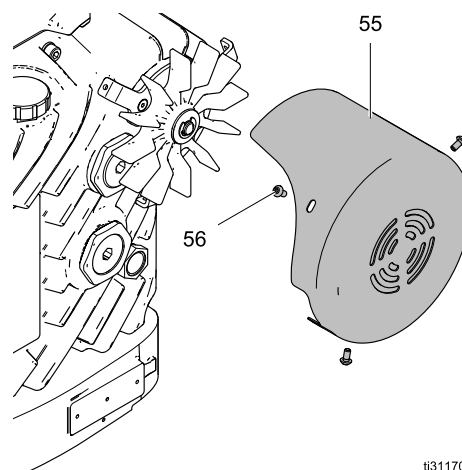

Fan Cover

55	Fan cover
56	Screws

3. Fill with oil. See [Fill the Oil](#), page 17.

Complete Fan Replacement Kit 26A395

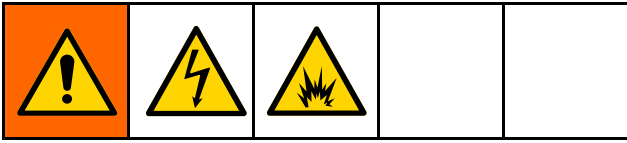

Tools Required

- 3 mm hex wrench
- 6 mm hex wrench
- Flathead screwdriver
- Snap ring pliers
- Torque wrench 20 ft-lb (27 N•m)

Remove the Fan

1. Follow the instructions in [Prepare for Repair, page 15](#).
2. Using a 3 mm hex wrench, remove the three fan cover screws (56) and then remove the cover (55).

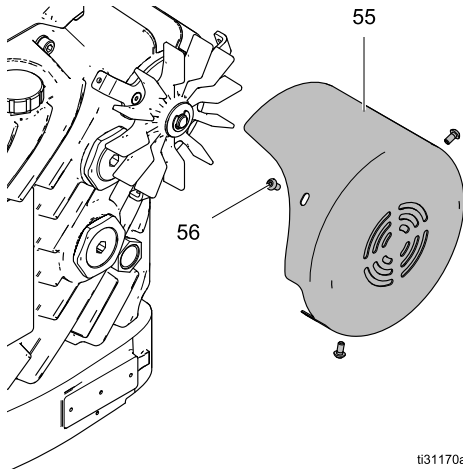

Fan Cover

55	Fan cover
56	Screws

3. Using a flathead screwdriver, remove the retaining clip (54).

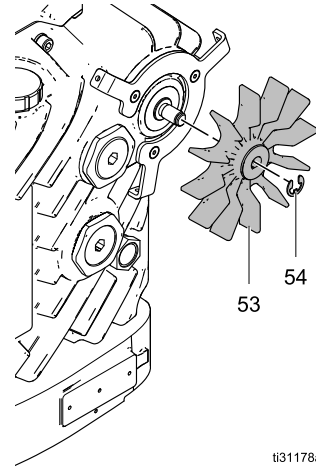

Fan

53	Fan
54	Retaining clip

4. Pull the fan (53) to remove it. It is a pressed-on fit. Be careful not to damage the seal (26).

Remove the Gear Cover

1. Using a 3 mm hex wrench, remove the three fan cover screws (56) and then remove the cover (55).

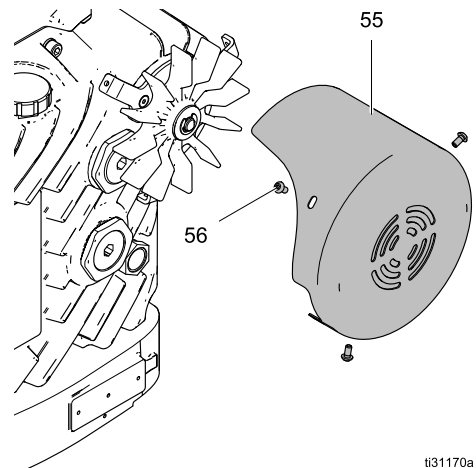

Fan Cover

55	Fan cover
56	Screws

2. Remove the eight 6 mm hex screws (24) and washers (43) from the gear cover (2).

3. The gear cover is mounted on two dowels. Pull the cover straight out to remove it.

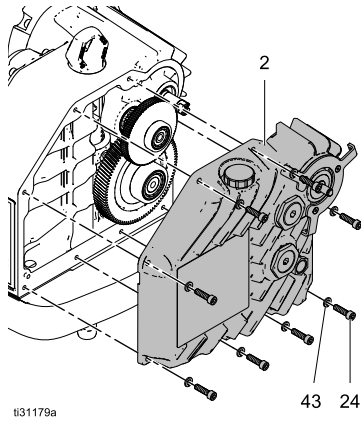

Gear Cover

2	Gear cover
24	Hex screws
43	Washer

Install the Fan Bearing Seal

1. Insert the fan bearing seal (26) into the gear cover.
2. Grease the shaft of the fan bearing assembly (49) and insert it into the fan bearing seal (26).
3. Reinstall the snap ring (48).
4. Insert the fan coupler (62) into the fan bearing assembly.
5. Press the new shaft seal (26) into the gear cover.

Remove the Fan Bearing Seal

1. Remove the fan coupler (62) from the gear cover (2).

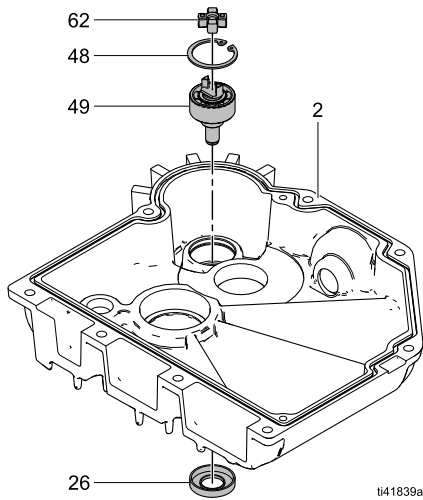

Fan Components

2	Gear cover
26	Fan bearing seal
48	Snap ring
49	Fan bearing assembly
62	Fan coupler

2. Using the snap ring pliers, remove the snap ring (48).
3. Pull out the fan bearing assembly (49).
4. Tap the edge of fan bearing seal (26) with a flat head screwdriver and hammer until it folds and can be pried out.

Install the Gear Cover

1. Place the gear cover on the motor housing and secure it with the eight 6 mm hex screws (24) and washers (43). Torque to 15 ft-lb (20 N•m).
2. Using a 3 mm hex wrench, secure the fan cover (55) with the three screws (56).

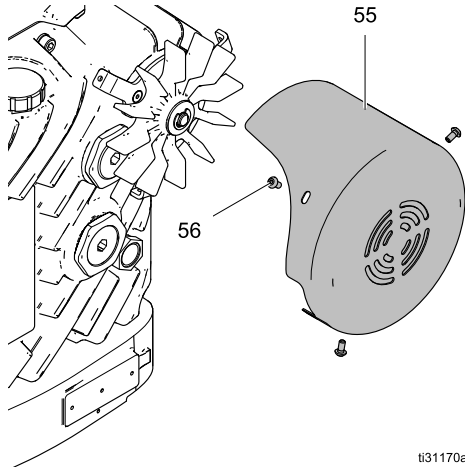

Fan Cover

55	Fan cover
56	Screws

3. Fill with oil. See [Fill the Oil](#), page 17.

Install the Fan

1. Press the fan (53) onto the fan shaft (49).
2. Attach the retaining clip (54) into the groove in the fan shaft, lining up the clearance flat of the shaft with the clip ends.
3. Using a 3 mm hex wrench, secure the fan cover (55) with the three screws (56).

Gear and Output Shaft Replacement Kits: 26A401 (series A/B), 26A398 (series C), and 26A399

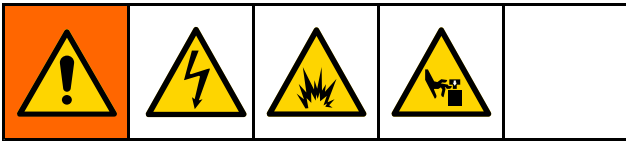

Tools Required

- 3 mm hex wrench
- 4 mm hex wrench
- 6 mm hex wrench
- 1/4 inch (10 mm) drive socket wrench
- Phillips screwdriver (#1)
- 2 inch wrench
- M5 socket wrench
- Torque wrenches
 - 80 ft-lbs (108 N•m)
 - 150 in-lb (17 N•m)
- Blue (medium) thread locking compound
- Grease

Remove the Fan and Gear Cover

1. Follow the instructions in [Prepare for Repair, page 15](#).
2. Using a 2 inch wrench, loosen the gear jam nuts (46) on the outside of the gear cover for later removal. See [Parts — Gear Box, page 8](#).
3. Using a 3 mm hex wrench, remove the three fan cover screws (56) and then remove the cover (55).

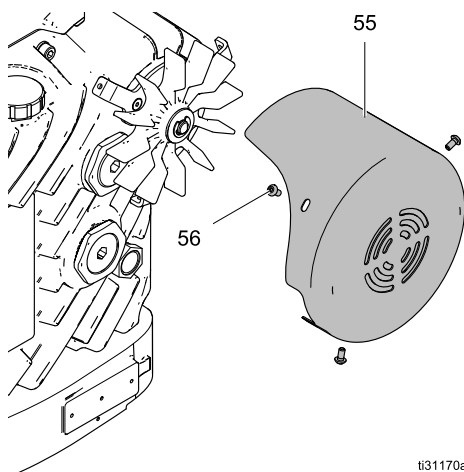

Fan Cover

55	Fan cover
56	Screws

4. Using a flathead screwdriver, remove the retaining clip (54).

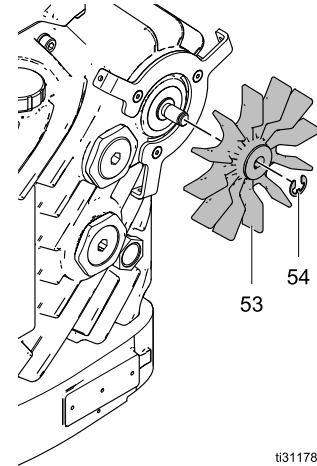

Fan

53	Fan
54	Retaining clip

5. Pull the fan (53) to remove it. It is a pressed-on fit. Be careful not to damage the seal (26).
6. Remove the eight 6 mm hex screws (24) and washers (43) from the gear cover (2).
7. The gear cover is mounted on two dowels. Pull the cover straight out to remove it.

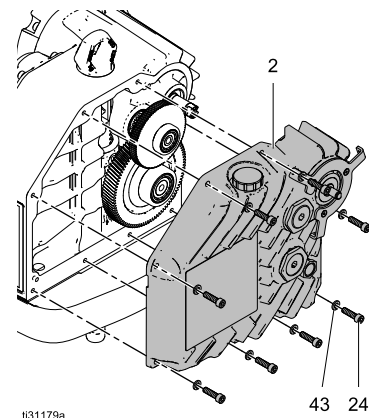

Gear Cover

2	Gear cover
24	Hex screws
43	Washer

Remove the 1st Stage Gear

Pull out the 1st stage gear (11). You might need to push the 2nd stage gear (10) aside to release the 1st stage gear.

Remove the 2nd Stage Gear and Output Shaft

1. Turn the 2nd stage gear (10) clockwise so the output shaft (18) is as high as possible in the motor housing.
2. Using a 2 inch wrench, loosen the output shaft bearing (19).
3. While holding the gear in place, remove the bearing, lower bumper (31), and support washer (12) from the output shaft.
4. While grasping the output shaft, remove it by rotating the 2nd stage gear (10) counterclockwise.
5. Remove the output shaft and 2nd stage gear at the same time.

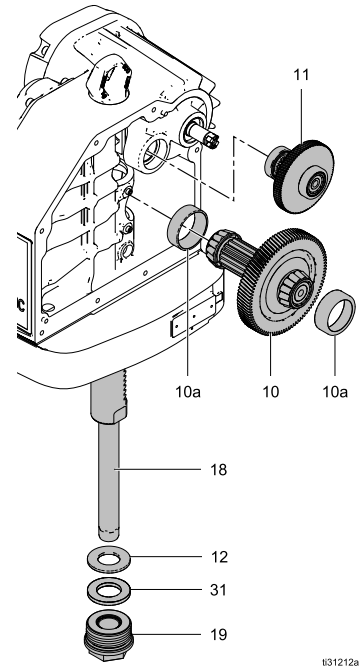

Gears and Output Shaft

10	2nd stage gear
10a	Outer race
11	1st stage gear
12	Support washer
18	Output shaft
19	Output shaft bearing
31	Lower bumper

Replace the Rotor Shaft Seal

1. Remove the input shaft seal (26) from the gear side of the motor housing (see [Parts — Gear Box, page 8](#) for location).
2. Install the new seal.

Replace the Bearing Race

Remove the 2nd stage gear bearing race (10a) from the motor housing and replace it with one from the kit.

Remove the Rack Bearing

Remove the two 4 mm hex screws (16) holding the rack bearing (17) in place. To remove the bearing, slide it sideways to release the snap feature, then down through the bottom of the output shaft.

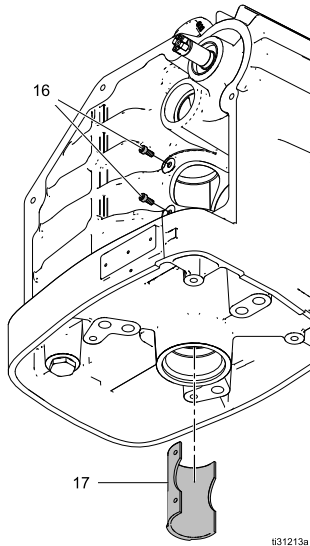

Rack Bearing

16	Screws
17	Rack bearing

Install the Rack Bearing

1. Put gear grease on the back of the rack bearing. Slide it into the motor housing until the lip on the bottom of the bearing snaps into place.
2. Line up the holes in the rack bearing with the holes in the motor housing.
3. Apply blue thread locking compound to the rack bearing screws (16). Insert the screws through the motor housing holes and into the bearing. Torque to 30 in-lbs (3 N•m).

Install the Output Shaft and 2nd Stage Gear

1. Grease the threads and o-ring of the output shaft bearing (19).
2. Apply gear oil or grease to the back of the output shaft (18) and insert the output shaft into the motor housing (1).
3. Hold the output shaft while inserting the 2nd stage gear (10), lining up the gears of each so they mesh.
4. Turn the gear clockwise until the output shaft has raised as high as possible and hold in place.
5. Slide the support washer (12), bumper (31), and output shaft bearing (19) onto the output shaft (18) as far as possible and hand tighten, then torque 70–80 ft-lbs (95 N•m).

Install the 1st Stage Gear

1. Slide the 1st stage gear (11) and bearing (11a) into the motor housing (1).
2. For 2 hp models, line up the 1st stage gear with the clearance flat of the fan drive on the rotor (77).
3. Line up the 1st stage gear with the 2nd stage gear (10) so that the gears mesh together.

Replace the Bearing Adjuster O-Rings

1. Remove the previously loosened jam nuts (46) from the outside of the gear cover.
2. Using a 10 mm drive, remove the gear adjusters (15, 44) from the inside of the gear cover.
3. Remove the o-rings (37 and 45) and clean the bearing adjuster threads.
4. Put the new o-rings (37 and 45) on the bearing adjusters.
5. Grease the o-ring area of both bearing adjusters.
6. Apply thread sealant on the threads of the adjusters.

- Use a 10 mm drive to install each adjuster into its appropriate hole.

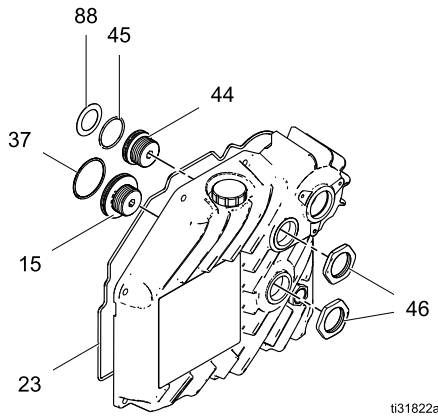

Gear Cover Components

15	2nd stage bearing adjuster
23	Gasket
37	O-ring, 2nd stage adjuster
44	1st stage bearing adjuster
45	O-ring, 1st stage adjuster
46	Jam nuts
88	Disc spring (Series A, B only)

Install the Gear Cover

- Remove and replace the gear cover gasket (23). Place grease on the gasket groove of the gear cover in three or four places before you press the gasket into place.
- Place the gear cover (2) on the motor housing and secure with the eight 6 mm hex screws (24) and washers (43). Torque to 15 ft-lb (20 N•m).

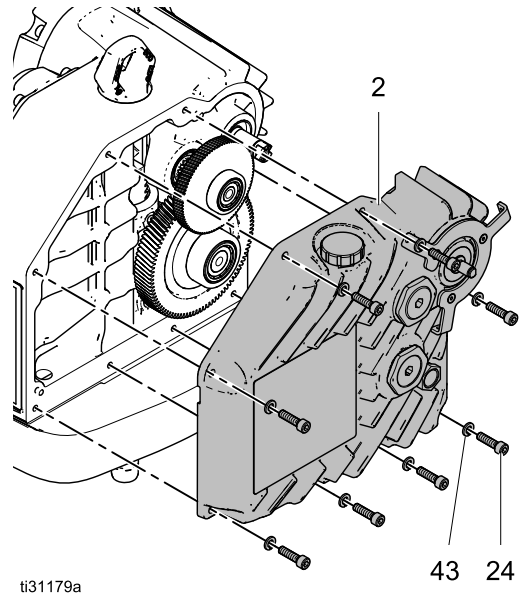

- Torque the 2nd stage adjuster (15) clockwise to 150 in-lbs (17 N•m). Back off several turns counterclockwise, and then torque the 2nd stage adjuster clockwise to 100 in-lbs (11 N•m).
- Torque the 1st stage adjuster (44) clockwise to 100 in-lbs (11 N•m). Back off several turns counterclockwise, and then torque the 1st stage adjuster clockwise to 70 in-lbs (8 N•m).
- Screw the jam nuts into the outside of the gear cover. Torque to 40 ft-lbs (54 N•m).

Install the Fan

- Press the fan (53) onto the fan shaft (49).
- Attach the retaining clip (54) into the groove in the fan shaft, lining up the clearance flat of the shaft with the clip ends.
- Using a 3 mm hex wrench, secure the fan cover (55) with the three screws (56).

Replace the Output Shaft Bearing

1. Unscrew and remove the output shaft bearing (19) from the motor. See [Parts — Gear Box, page 8](#).
2. Install the new bearing (19), bumper (31), and washer (12). Torque to 70 ft-lb (95 N•m).
3. Fill with oil. See [Fill the Oil, page 17](#).
4. Reconnect the lower to the motor.

Rotor Replacement Kit 26A397

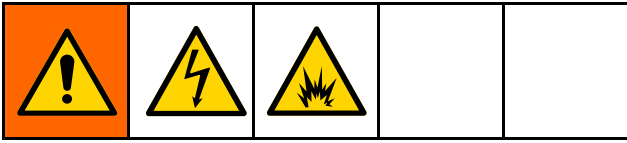

Tools Required

- 4 mm hex wrench
- 6 mm hex wrench
- 13 mm hex wrench
- .050 in hex wrench
- Phillips screwdriver (#1)
- Flathead screwdriver
- Torque wrench 15–20 ft-lb (20–27 N•m)
- Torque wrench 100 in-lb (11 N•m)
- Blue (medium) thread locking compound

Remove the Motor Cover

1. Follow the instructions in [Prepare for Repair, page 15](#).
2. Using a 6 mm hex wrench, remove the four bolts (24) and washers (43) that are securing the motor cover.

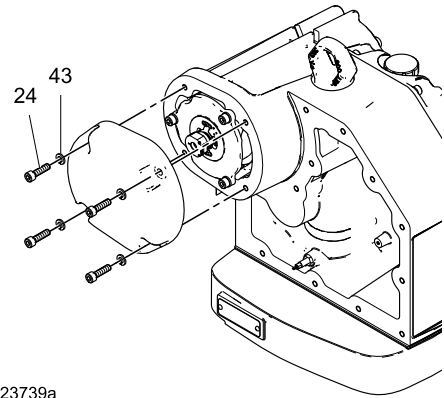

ti23739a

Motor Cover

Remove the Encoder

1. Unplug the cable from the encoder (21).
2. Using the .050 in hex wrench, loosen the two hub set screws (AA) from the sides of the encoder. Do not remove the screws.

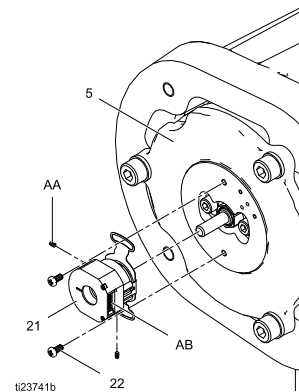

ti23741b

Encoder

AA	Set screws
AB	Encoder mounting flange
5	Rotor support
21	Encoder
22	Phillips head mounting screws

3. Using a Phillips head screwdriver, remove the two encoder mounting screws (22).

- Pull the encoder off the rotor support (5).
If the encoder is older, like the one below, do not reinstall it. Order a new encoder (P/N 16U935) to replace it.

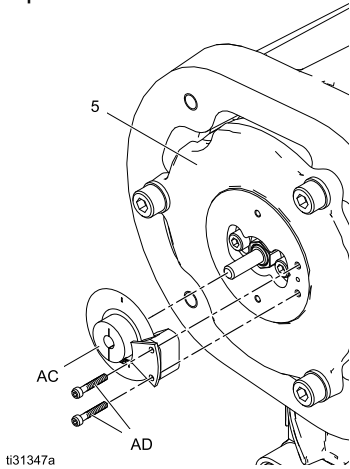

- Remove the rotor (77) by manually pulling it out. Be careful not to let the rotor pull back into the stator.

NOTICE

The rotor is a very strong magnet. Keep it away from sensitive equipment such as cell phones, cameras, credit cards, and so on.

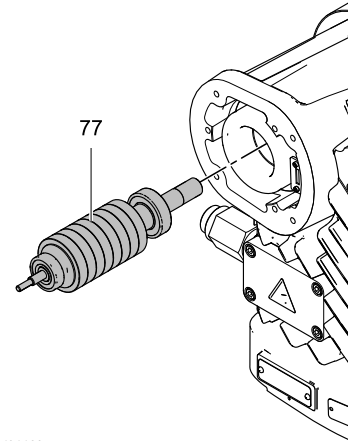

Remove the Rotor

- Using a 6 mm wrench, remove three screws (24) and washers (43) from the rotor support (5). Be careful not to scratch any surfaces.

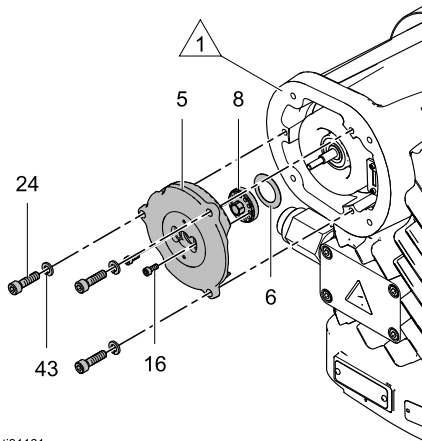

Rotor Support

5	Rotor support
6	Disc spring
8	Rotor adjuster
16	Screws
24	Screws
43	Washers
⚠	Do not damage the surface.

Rotor

77	Rotor
----	-------

Remove the Gear Cover

- Using a 3 mm hex wrench, remove the three fan cover screws (56) and then remove the cover (55).

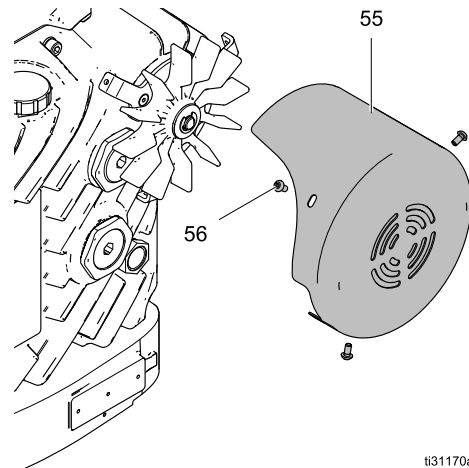

Fan Cover

55	Fan cover
56	Screws

- Remove the eight 6 mm hex screws (24) and washers (43) from the gear cover (2).

Rotor Replacement Kit 26A397

- The gear cover is mounted on two dowels. Pull the cover straight out to remove it.

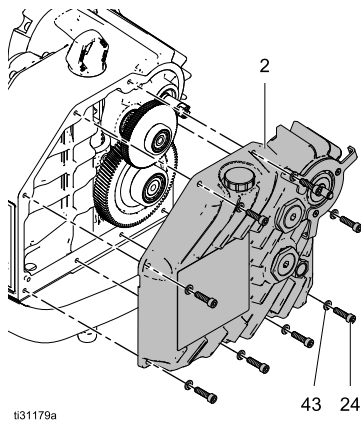

ti31179a

Gear Cover

2	Gear cover
24	Hex screws
43	Washer

- Place the spring disc (6) on the rotor shaft as shown below.

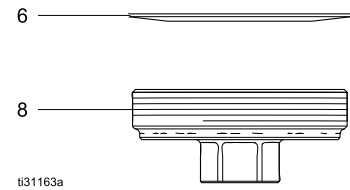

ti31163a

Disc Spring Placement

6	Disc spring
8	Rotor adjuster

- Replace the rotor support (5) and insert the three screws (24) and washers (43). Torque to 15 ft-lb (20 N•m).
- Tighten the rotor adjuster clockwise to 100 in-lb (11 N•m) to set the rotor. Back out several turns counterclockwise and then tighten to 15 in-lbs (1.5 N•m).
- Insert the two locking screws (16). Torque to 30 in-lbs (3 N•m).

Replace the Rotor Shaft Seal

- Remove the input shaft seal (26) from the gear side of the motor housing (see [Parts — Gear Box, page 8](#) for location).
- Install the new seal.

Install the Rotor

- Grease the rotor shaft (77).

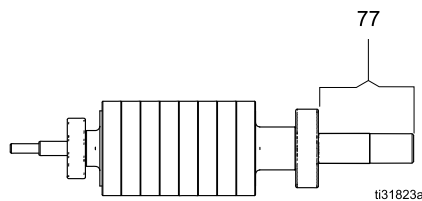

ti31823a

- Insert the rotor into the motor housing by holding the bearing. Be careful of your fingers. The rotor pulls itself in.

NOTICE

Make sure the rotor seats properly. If the rotor does not seat properly, equipment damage will result.

- Remove the two 4 mm locking screws (16) securing the rotor adjuster (8) to the rotor support (5). Keep the rotor adjuster in place in the rotor support.
- Place a 13 mm socket in the outside center hole of the rotor support and turn it counterclockwise as far as possible to loosen the position of the rotor adjuster.

Install the Encoder

- Place the encoder connector cable (AE) through the motor housing lower port (AF).

NOTE: The encoder connector is the smaller of the two connections.

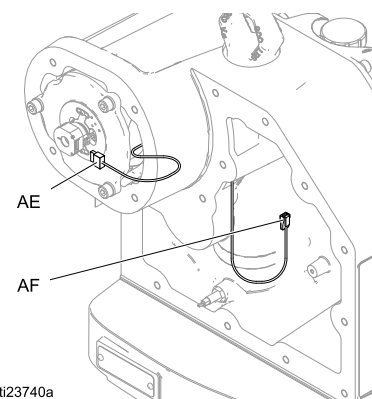

ti23740a

Encoder Cable

AE	Encoder connector cable
AF	Lower port of motor housing

- Slide the new encoder onto the rotor shaft.
- Apply a small amount of blue (medium) thread locker to the two Phillips head mounting screws (AC). Secure the encoder mounting flange (AB) to the motor housing (AD).
- Using the included .050 inch hex wrench, remove the two set screws (AA) from the encoder hub.
- Apply a small amount of blue (medium) thread locker to the set screws (AA) and screw them back into the encoder. Tighten by hand.

6. Plug the encoder cable into the encoder and the control board.

Install the Motor Cover

1. Reinstall the motor cover onto the motor housing.
2. Using a 6 mm hex wrench, install the four bolts (24) and washers (43) that hold the motor cover. Torque the bolts to 15 ft-lb (20 N•m).

Install the 1st Stage Gear

1. Slide the 1st stage gear (11) and bearing (11a) into the motor housing (1).
2. For 2 hp models, line up the 1st stage gear with the clearance flat of the fan drive on the rotor (77).
3. Line up the 1st stage gear with the 2nd stage gear (10) so that the gears mesh together.

Install the Gear Cover

1. Place the gear cover on the motor housing and secure it with the eight 6 mm hex screws (24) and washers (43). Torque to 15 ft-lb (20 N•m).

2. Using a 3 mm hex wrench, secure the fan cover (55) with the three screws (56).

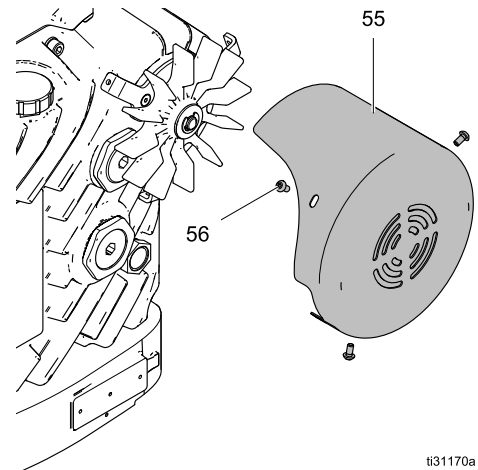

Fan Cover

55	Fan cover
56	Screws

3. Fill with oil. See [Fill the Oil, page 17](#).

Control Board Replacement Kits 24U934, 24U936, 24U935, 24U937

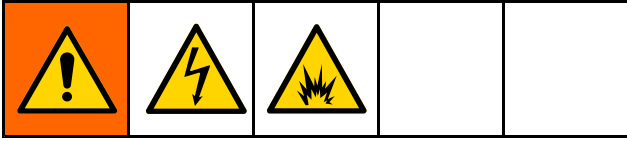

Overview

The main control board assembly manages the operation of the E-Flo DC. It is permanently attached to the electronics cover.

Tools Required

- 6 mm hex wrench
- Phillips screwdriver (#1)
- Torque wrench 15 ft-lb (20 N•m)

Disconnect the Power Wires

1. Follow the instructions in [Prepare for Repair, page 15](#).
2. Using a 6 mm hex wrench, remove the four bolts that hold the wiring box cover. Place the bolts in a safe location.
3. Disconnect the wires from the post and ground the screw inside the cover.
4. Remove the power cable and conduit from the electronics cover.

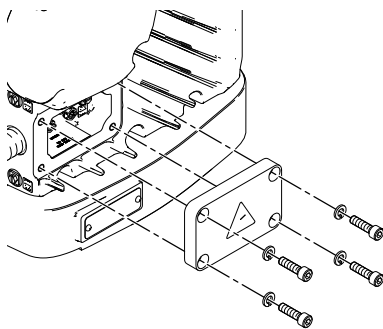

ti23734a

Wiring Box Cover

Remove the Electronics Cover

NOTICE

To avoid equipment damage, carefully support the cover when removing the last bolt. Hold the cover horizontally and take care that the wires are not pulled tight.

1. Using a 6 mm hex wrench, remove the 12 bolts that hold the electronics cover.

2. Support the cover after the bolts are removed to prevent excess strain on the wires inside the E-Flo DC.

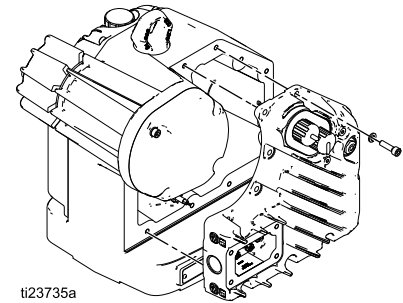

ti23735a

Electronics Cover

Disconnect the Control Board

NOTE: The control board is inside the electronics cover. To replace the control board, you must replace the entire electronics cover.

1. Unplug the position sensor, encoder, temperature sensor, and motor from the control board.
2. Remove the wires from the clip inside the housing.
3. Remove any tie straps that are present.
4. Set the electronics cover and control board aside.

For advanced models, see [Disconnect the Power Barrier Board, page 41](#).

Install the New Control Board

1. Plug the position sensor, encoder, temperature sensor, and motor into the new control board.

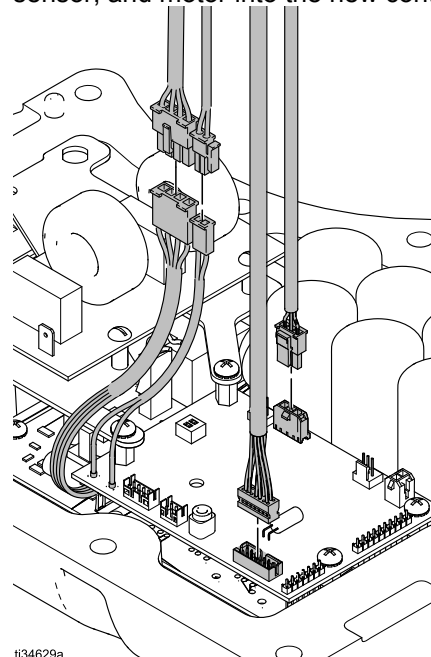

ti34629a

- Secure the loose wires into the clip inside the housing.

For advanced models, see [Install the New Power Barrier Board, page 43](#).

Reset the Dip Switch

To calibrate the unit, you must toggle a dip switch on the control board. There are two dip switches located on the upper control board to calibrate the unit. Reset either dip switch by toggling it to the opposite state. This signals the control board that a replacement part has been installed. The next time the unit is powered, it runs an automatic calibration sequence.

NOTE: If you are performing more than one repair procedure, the dip switch only needs to be toggled into the opposite state once.

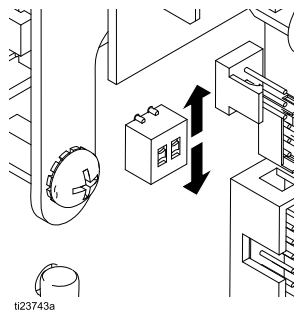

Dip Switch

Reinstall the Electronics Cover

<p>Be sure that no wires are pinched between the electronics cover and the motor housing. Pinched wires may damage the control board and will impair explosion-proof safety.</p>				

- Reinstall the electronics cover onto the center housing.
- Using a 6 mm hex wrench, install the 12 bolts.
NOTE: Ensure that the lock washers are still in place.
- Torque the bolts to 15 ft-lb (20 N•m).

Reinstall the Wiring Box Cover

- Connect the wires from the inside of the wiring box. Refer to the torque instructions listed on the placard inside of the wiring box. Connect the power cable and/or conduit to the electronics cover.
- Reinstall the cover onto the wiring box.
- Using a 6 mm hex wrench, install the four bolts.
NOTE: Ensure the lock washers are still in place.
- Torque the bolts to 15 ft-lb (20 N•m).

Apply Power to the Unit

- Apply power to the unit to start the automatic calibration process. The motor output shaft runs up and down over the course of several minutes. Halfway through the automatic calibration process, the motor output shaft pauses as it moves to the next step.
- Ensure that the automatic calibration process is complete before you continue.

Reattach the Pump Lower

- Jog the output shaft on the pump lower and reconnect the coupling nut.
- Torque to the proper level according to the appropriate pump manual.

Encoder Replacement Kit 24U938

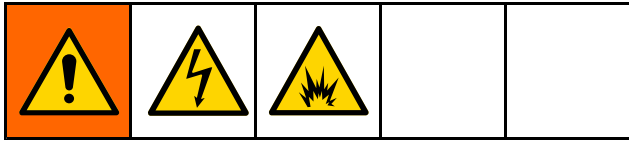

Overview

The E-Flo DC uses the encoder for two purposes:

- The encoder informs the control board where the motor is in its mechanical rotation and uses that information to properly control the motor torque.
- The encoder controls stroke length by allowing the control board to count the number of complete motor rotations.

Tools Required

- 6 mm hex wrench
- .050 in hex wrench
- Phillips screwdriver (#1)
- Torque wrench 15 ft-lb (20 N•m)
- Blue (medium) thread locking compound

Remove the Electronics Cover

NOTICE

To avoid equipment damage, carefully support the cover when removing the last bolt. Hold the cover horizontally and take care that the wires are not pulled tight.

1. Follow the instructions in [Prepare for Repair, page 15](#).
2. Using a 6 mm hex wrench, remove the 12 bolts that hold the electronics cover.
3. Support the cover after the bolts are removed to prevent excess strain on the wires inside the E-Flo DC.

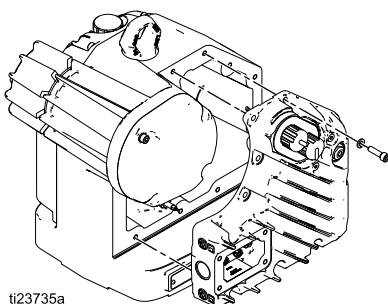

ti23735a

Electronics Cover

Remove the Motor Cover

Using a 6 mm hex wrench, remove the four bolts (24) and washers (43) that are securing the motor cover.

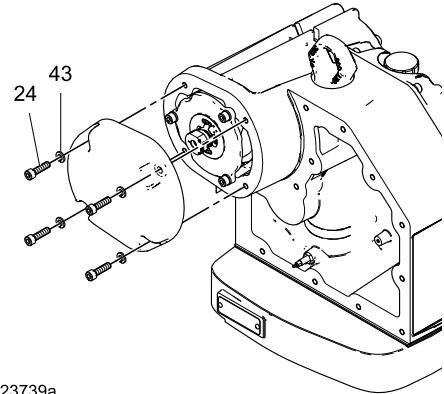

ti23739a

Motor Cover

Remove the Encoder

1. Unplug the cable from the encoder (21).
2. Using the .050 in hex wrench, loosen the two hub set screws (AA) from the sides of the encoder. Do not remove the screws.

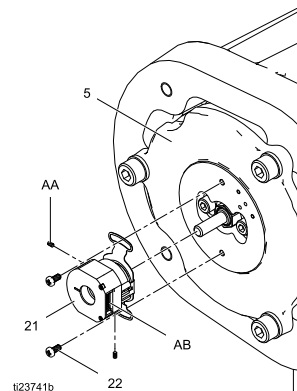

ti23741b

Encoder

AA	Set screws
AB	Encoder mounting flange
5	Rotor support
21	Encoder
22	Phillips head mounting screws

3. Using a Phillips head screwdriver, remove the two encoder mounting screws (22).

4. Pull the encoder off the rotor support (5).

If the encoder is older, like the one below, do not reinstall it. Order a new encoder (P/N 16U935) to replace it.

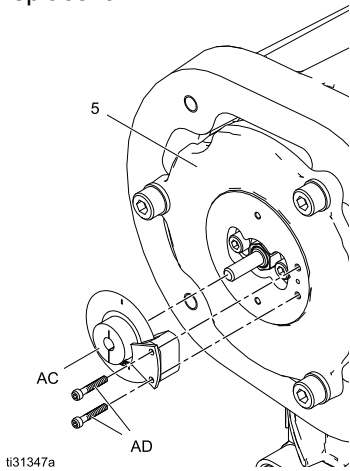

Install the Encoder

1. Place the encoder connector cable (AE) through the motor housing lower port (AF).

NOTE: The encoder connector is the smaller of the two connections.

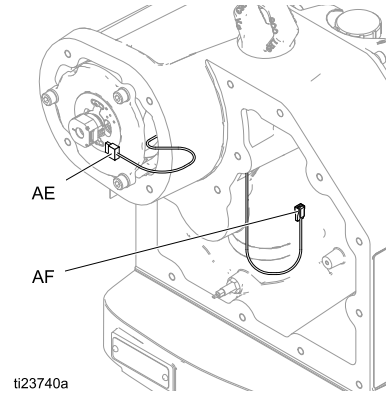

Encoder Cable

AE	Encoder connector cable
AF	Lower port of motor housing

2. Slide the new encoder onto the rotor shaft.
3. Apply a small amount of blue (medium) thread locker to the two Phillips head mounting screws (AC). Secure the encoder mounting flange (AB) to the motor housing (AD).
4. Using the included .050 inch hex wrench, remove the two set screws (AA) from the encoder hub.
5. Apply a small amount of blue (medium) thread locker to the set screws (AA) and screw them back into the encoder. Tighten by hand.
6. Plug the encoder cable into the encoder and the control board.

Reset the Dip Switch

To calibrate the unit, you must toggle a dip switch on the control board. There are two dip switches located on the upper control board to calibrate the unit. Reset either dip switch by toggling it to the opposite state. This signals the control board that a replacement part has been installed. The next time the unit is powered, it runs an automatic calibration sequence.

NOTE: If you are performing more than one repair procedure, the dip switch only needs to be toggled into the opposite state once.

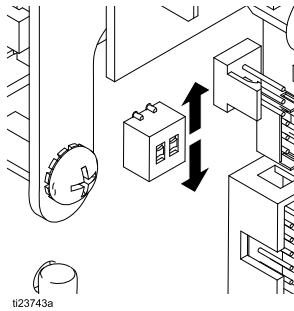

Dip Switch

Reinstall the Electronics Cover

<p>Be sure that no wires are pinched between the electronics cover and the motor housing. Pinched wires may damage the control board and will impair explosion-proof safety.</p>				

1. Reinstall the electronics cover onto the center housing.
2. Using a 6 mm hex wrench, install the 12 bolts.
NOTE: Ensure that the lock washers are still in place.
3. Torque the bolts to 15 ft-lb (20 N•m).

Reinstall the Motor Cover

1. Reinstall the motor cover onto the motor housing.

2. Using a 6 mm hex wrench, install the four bolts that hold the motor cover. Ensure that the lock washers are still in place.
3. Torque the bolts to 15 ft-lb (20 N•m).

Apply Power to the Motor

NOTE: Alarm code END_ (blink code 5–6) appears during this sequence and disappears when the sequence is complete.

1. Apply power to the motor to start the automatic calibration process.
2. Wait for the motor to go through the calibration sequence.
 - a. The motor slowly goes through five complete cycles.
 - b. The motor moves toward the center of the stroke and moves up and down within a small range very slowly.
NOTE: It might not be obvious that the motor is moving.
 - c. The motor pauses for a few seconds.
 - d. If the encoder calibration is successful, the motor proceeds to calibrate the stroke changeover position, which is ten quick cycles.
 - e. When calibration has successfully completed, the DIP switch position are saved.
NOTE: Do not return the DIP switches to the original position unless you want to cancel the calibration.
 - f. The motor resets itself.
3. Ensure that the automatic calibration process is complete before you continue.

Reattach the Pump Lower

1. Jog the output shaft on the pump lower and reconnect the coupling nut.
2. Torque to the proper level according to the appropriate pump manual.

Position Sensor Replacement Kit 24W920

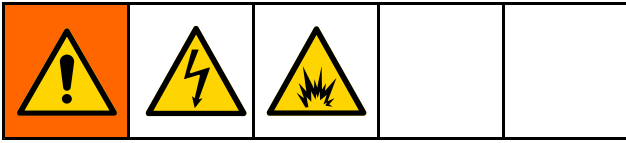

Overview

The E-Flo DC uses the position sensor to determine where the motor is in the stroke.

Tools Required

- 6 mm hex wrenches
- 13 mm open-ended wrench
- 6 mm open-ended wrench
- Phillips screwdriver (#2)
- Torque wrench 15 ft-lb (20 N•m)

Remove the Electronics Cover

NOTICE

To avoid equipment damage, carefully support the cover when removing the last bolt. Hold the cover horizontally and take care that the wires are not pulled tight.

1. Follow the instructions in [Prepare for Repair, page 15](#).
2. Using a 6 mm hex wrench, remove the 12 bolts that hold the electronics cover.
3. Support the cover after the bolts are removed to prevent excess strain on the wires inside the E-Flo DC.

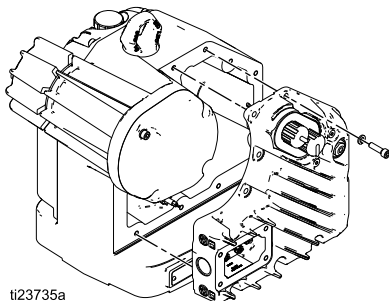

ti23735a

Electronics Cover

Remove the Position Sensor

1. Unplug the position sensor from the control board.

3A4801E

2. Using a 13 mm wrench, loosen the position sensor jam nut (AS).
3. Using a 6 mm open ended wrench, unscrew the position sensor (AR) from the center housing.

NOTE: Allow the wires to rotate with the position sensor to prevent twisting.

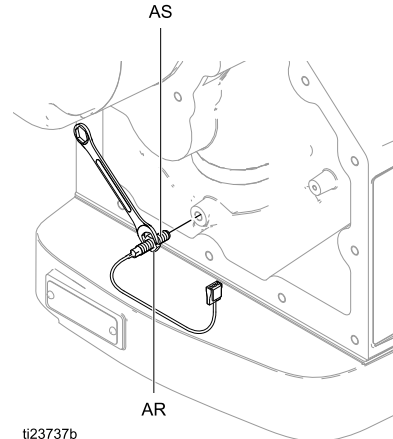

ti23737b

Position Sensor

AR	Position sensor
AS	Jam nut
AT	Shield ground

Install the New Position Sensor

1. Carefully screw the replacement position sensor into the center housing.

NOTE: Be careful not to damage the wires. Rotate the wires while the position sensor is installed to prevent the wires from being twisted.

2. Use the 6 mm wrench to complete the installation of the position sensor. Do not use excessive torque. Stop once the position sensor bottoms out in the bore.

NOTE: Do not over tighten the position sensor. Damage to the position sensor may result.

3. Using your fingers, tighten the jam nut on the position sensor.

NOTE: Do NOT use a wrench to tighten the jam nut. Damage to the position sensor may result.

Position Sensor Replacement Kit 24W920

4. Plug the position sensor into the control board.

NOTE: If you are replacing an older position sensor (see below), use the conversion wiring harness.

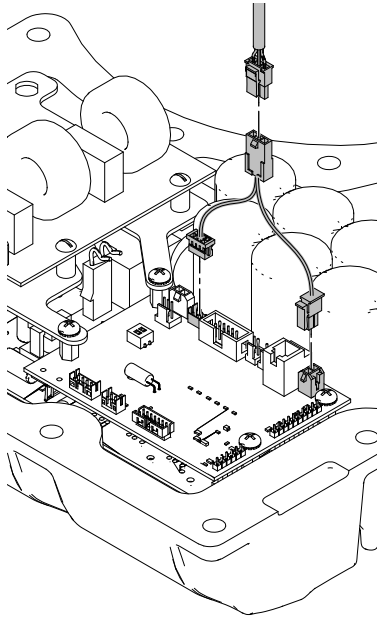

u31825a

Reset the Dip Switch

To calibrate the unit, you must toggle a dip switch on the control board. There are two dip switches located on the upper control board to calibrate the unit. Reset either dip switch by toggling it to the opposite state. This signals the control board that a replacement part has been installed. The next time the unit is powered, it runs an automatic calibration sequence.

NOTE: If you are performing more than one repair procedure, the dip switch only needs to be toggled into the opposite state once.

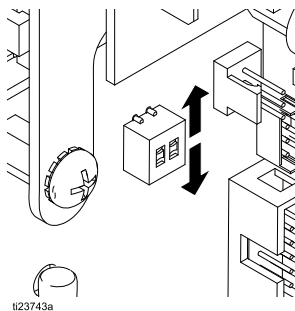

u23743a

Dip Switch

Reinstall the Electronics Cover

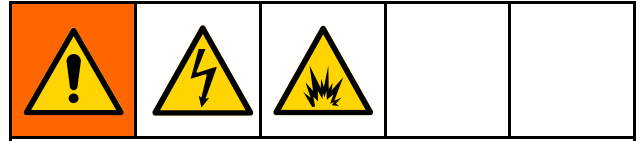

Be sure that no wires are pinched between the electronics cover and the motor housing. Pinched wires may damage the control board and will impair explosion-proof safety.

1. Reinstall the electronics cover onto the center housing.
2. Using a 6 mm hex wrench, install the 12 bolts.
NOTE: Ensure that the lock washers are still in place.
3. Torque the bolts to 15 ft-lb (20 N•m).

Apply Power to the Unit

1. Apply power to the unit to start the automatic calibration process. The motor output shaft runs up and down over the course of several minutes. Halfway through the automatic calibration process, the motor output shaft pauses as it moves to the next step.
2. Ensure that the automatic calibration process is complete before you continue.

Reattach the Pump Lower

1. Jog the output shaft on the pump lower and reconnect the coupling nut.
2. Torque to the proper level according to the appropriate pump manual.

Advanced Power Board Replacement Kit 24U939

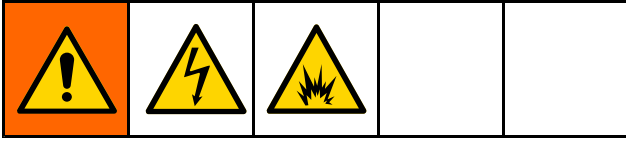

Tools Required

- 6 mm hex wrenches
- 1/4 inch nut driver
- 5 mm hex wrench
- Phillips screwdriver (#2)
- Torque wrench 15 ft-lb (20 N•m)

Disconnect the Power Wires

1. Follow the instructions in [Prepare for Repair, page 15](#).
2. Using a 6 mm hex wrench, remove the four bolts that hold the wiring box cover. Place the bolts in a safe location.
3. Disconnect the wires from the post and ground the screw inside the cover.
4. Remove the power cable and conduit from the electronics cover.

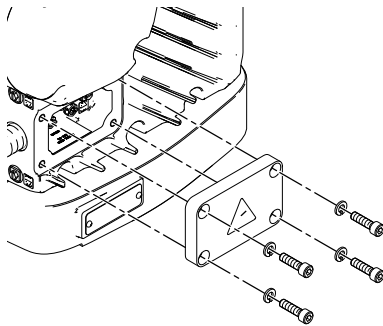

ti23734a

Wiring Box Cover

Remove the Control Module Bracket

If the control module is bracket mounted to the electronics cover, remove it before you remove the electronics cover.

1. Unsnap the control module from the bracket and disconnect the cable from the electronics cover. Set the control module aside.

2. Remove the control module bracket from the electronics cover. Set the bracket and hardware aside.

Remove the Electronics Cover

NOTICE

To avoid equipment damage, carefully support the cover when removing the last bolt. Hold the cover horizontally and take care that the wires are not pulled tight.

1. Using a 6 mm hex wrench, remove the 12 bolts that hold the electronics cover.
2. Support the cover after the bolts are removed to prevent excess strain on the wires inside the E-Flo DC.

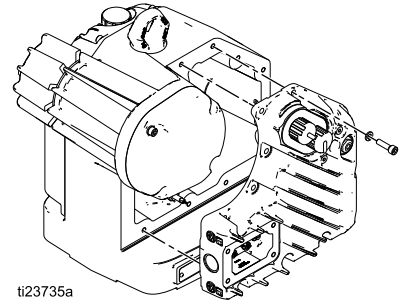

ti23735a

Electronics Cover

Disconnect the Power Barrier Board

NOTICE

The CAN bus on the power barrier board is connected to the control board through a partition inside the motor. To avoid equipment damage, hold the electronics cover in place until the CAN bus cable is disconnected. Hold the cover horizontally and make sure that the wires are not pulled tight.

1. Disconnect barrier board power cable from the control board.
2. Remove the four screws (AK) holding the partition (AL) and power cable bracket (AJ) in place. Set them aside.
3. Remove any tie straps that are present.

Advanced Power Board Replacement Kit 24U939

4. Insert a small hex key into the lower left corner of the partition and pull it out.

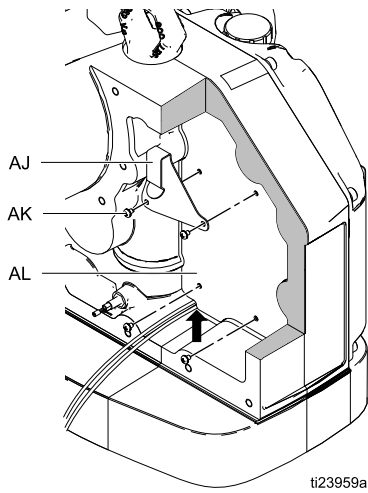

Electronic Partition

AJ	Cable bracket
AK	Screw
AL	Partition

5. Remove the tie strap connecting the CAN bus wire to the power barrier board (AN).
6. Use a 1/4 inch nut driver to remove the four stand offs (AM) from the corners of the power barrier board. Set them aside.

7. Use a 5 mm hex wrench to remove the two socket headed cap screws (AP) from the power barrier board. Set them aside.
8. Remove the power barrier board (AN) from the unit.

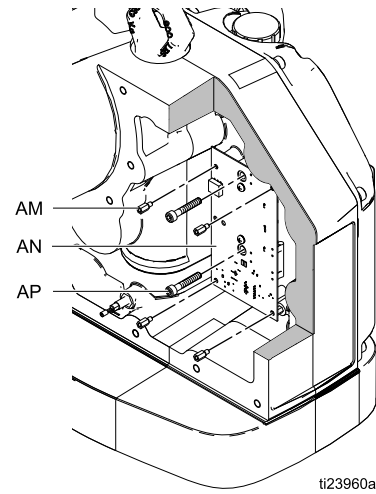

Power Barrier Board

AM	Stand off
AN	Power barrier board
AP	Socket head cap screw

Install the New Power Barrier Board

1. Insert the tie strap through the back of the power barrier board.
2. Put the new power barrier board in place and secure it using the reserved screws. Tighten the standoffs by hand. Torque the socket head cap screws to 15 ft-lb (20 N•m).
NOTE: Put all six screws in place before tightening. Tighten the standoffs before the socket head cap screws.
3. Plug the CAN bus power into the power barrier board.
4. Tighten the tie strap around the wires to secure them to the board.
5. Put the partition back into place. Make certain that the notch for the wires is on the lower left side of the partition and that the wires are not being crushed.
6. Insert the bottom screws into the partition and tighten.
7. Place the power connect bracket into place and secure it with two screws.
8. Reconnect the motor, temperature, reed switch, encoder, and barrier board power wires to the control board.

Reinstall the Electronics Cover

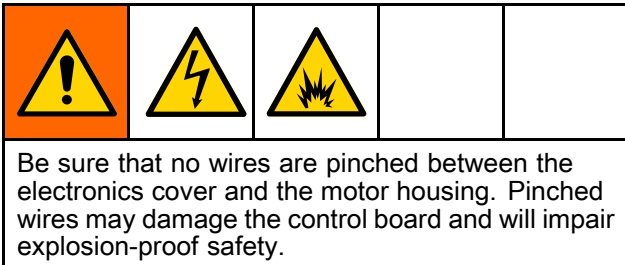

1. Reinstall the electronics cover onto the center housing.
2. Using a 6 mm hex wrench, install the 12 bolts.
NOTE: Ensure that the lock washers are still in place.
3. Torque the bolts to 15 ft-lb (20 N•m).

Reinstall the Wiring Box Cover

1. Connect the wires from the inside of the wiring box. Refer to the torque instructions listed on the placard inside of the wiring box. Connect the power cable and/or conduit to the electronics cover.
2. Reinstall the cover onto the wiring box.
3. Using a 6 mm hex wrench, install the four bolts.
NOTE: Ensure the lock washers are still in place.
4. Torque the bolts to 15 ft-lb (20 N•m).

3A4801E

Attach the Control Module Bracket

1. Connect the control module cable to the electronics cover.
2. Reattach the control module mounting bracket onto the electronics cover.
3. Snap the control module into place on the bracket.

Apply Power to the Unit

1. Apply power to the unit to start the automatic calibration process. The motor output shaft runs up and down over the course of several minutes. Halfway through the automatic calibration process, the motor output shaft pauses as it moves to the next step.
2. Ensure that the automatic calibration process is complete before you continue.

Reattach the Pump Lower

1. Jog the output shaft on the pump lower and reconnect the coupling nut.
2. Torque to the proper level according to the appropriate pump manual.

Technical Specifications

E-Flo DC Motors	U.S.	Metric
Input voltage/Power:		
Models EM0011, EM0012, EM0013, EM0014, EM0015, EM0016	100–130/ 200–240 VAC single phase, 50/60 Hz, 1.4 kVA	
Models EM0021, EM0022, EM0023, EM0024, EM0025, EM0026	200–240 VAC, single phase, 50/60 Hz, 2.9 kVA	
Models EM1011, EM1012, EM1013 , EM1014, EM1015, EM1016	380–480 VAC three phase, 50/60 Hz, 1.5 kVA	
Models EM1021, EM1022, EM1023, EM1024, EM1025, EM1026	380–480 VAC three phase, 50/60 Hz, 3.0 kVA	
Maximum potential fluid pressure:		
Models EM0011, EM0012, EM0013, EM0014, EM0015, EM0016, EM1011, EM1012, EM1013 , EM1014, EM1015, EM1016	218000/v (volume of lower in cc) = psi	1500/v (volume of lower in cc) = bar
Models EM0021, EM0022, EM0023, EM0024, EM0025, EM0026	436000/v (volume of lower in cc) = psi	3000/v (volume of lower in cc) = bar
Models EM1021, EM1022, EM1023, EM1024, EM1025, EM1026	500000/v (volume of lower in cc) = psi	3440/v (volume of lower in cc) = bar
Maximum continuous cycle rate		
20 cpm		
Maximum force:		
Models EM0011, EM0012, EM0013, EM0014, EM0015, EM0016, EM1011, EM1012, EM1013 , EM1014, EM1015, EM1016	1400 lbf	6227 N
Models EM0021, EM0022, EM0023, EM0024, EM0025, EM0026	2800 lbf	12455 N
Models EM1024, EM1026, EM1021, EM1023, EM1022, EM1025	3500 lbf	15570 N
Power inlet port size		
3/4–14 npt(f)		
Ambient temperature range		
32–104°F		0–40°C
Sound data		
Less than 70 dB(A)		
Oil capacity		
1.5 quarts		1.4 liters
Oil specification		
Graco Part No. 16W645 ISO 220 silicone-free synthetic gear oil		
Weight		
99 lb		45 kg

Graco Standard Warranty

Graco warrants all equipment referenced in this document which is manufactured by Graco and bearing its name to be free from defects in material and workmanship on the date of sale to the original purchaser for use. With the exception of any special, extended, or limited warranty published by Graco, Graco will, for a period of twelve months from the date of sale, repair or replace any part of the equipment determined by Graco to be defective. This warranty applies only when the equipment is installed, operated and maintained in accordance with Graco's written recommendations.

This warranty does not cover, and Graco shall not be liable for general wear and tear, or any malfunction, damage or wear caused by faulty installation, misapplication, abrasion, corrosion, inadequate or improper maintenance, negligence, accident, tampering, or substitution of non-Graco component parts. Nor shall Graco be liable for malfunction, damage or wear caused by the incompatibility of Graco equipment with structures, accessories, equipment or materials not supplied by Graco, or the improper design, manufacture, installation, operation or maintenance of structures, accessories, equipment or materials not supplied by Graco.

This warranty is conditioned upon the prepaid return of the equipment claimed to be defective to an authorized Graco distributor for verification of the claimed defect. If the claimed defect is verified, Graco will repair or replace free of charge any defective parts. The equipment will be returned to the original purchaser transportation prepaid. If inspection of the equipment does not disclose any defect in material or workmanship, repairs will be made at a reasonable charge, which charges may include the costs of parts, labor, and transportation.

THIS WARRANTY IS EXCLUSIVE, AND IS IN LIEU OF ANY OTHER WARRANTIES, EXPRESS OR IMPLIED, INCLUDING BUT NOT LIMITED TO WARRANTY OF MERCHANTABILITY OR WARRANTY OF FITNESS FOR A PARTICULAR PURPOSE.

Graco's sole obligation and buyer's sole remedy for any breach of warranty shall be as set forth above. The buyer agrees that no other remedy (including, but not limited to, incidental or consequential damages for lost profits, lost sales, injury to person or property, or any other incidental or consequential loss) shall be available. Any action for breach of warranty must be brought within two (2) years of the date of sale.

GRACO MAKES NO WARRANTY, AND DISCLAIMS ALL IMPLIED WARRANTIES OF MERCHANTABILITY AND FITNESS FOR A PARTICULAR PURPOSE, IN CONNECTION WITH ACCESSORIES, EQUIPMENT, MATERIALS OR COMPONENTS SOLD BUT NOT MANUFACTURED BY GRACO. These items sold, but not manufactured by Graco (such as electric motors, switches, hose, etc.), are subject to the warranty, if any, of their manufacturer. Graco will provide purchaser with reasonable assistance in making any claim for breach of these warranties.

In no event will Graco be liable for indirect, incidental, special or consequential damages resulting from Graco supplying equipment hereunder, or the furnishing, performance, or use of any products or other goods sold hereto, whether due to a breach of contract, breach of warranty, the negligence of Graco, or otherwise.

FOR GRACO CANADA CUSTOMERS

The Parties acknowledge that they have required that the present document, as well as all documents, notices and legal proceedings entered into, given or instituted pursuant hereto or relating directly or indirectly hereto, be drawn up in English. Les parties reconnaissent avoir convenu que la rédaction du présente document sera en Anglais, ainsi que tous documents, avis et procédures judiciaires exécutés, donnés ou intentés, à la suite de ou en rapport, directement ou indirectement, avec les procédures concernées.

Graco Information

For the latest information about Graco products, visit www.graco.com. For patent information, see www.graco.com/patents.

To place an order, contact your Graco Distributor or call to identify the nearest distributor.

Phone: 612-623-6921 **or Toll Free:** 1-800-328-0211 **Fax:** 612-378-3505

All written and visual data contained in this document reflects the latest product information available at the time of publication.

Graco reserves the right to make changes at any time without notice.

Original Instructions. This manual contains English, MM 3A4801

Graco Headquarters: Minneapolis

International Offices: Belgium, China, Japan, Korea

GRACO INC. AND SUBSIDIARIES • P.O. BOX 1441 • MINNEAPOLIS, MN 55440-1441 • USA
Copyright 2022, Graco Inc. All Graco manufacturing locations are registered to ISO 9001.

www.graco.com
Revision E, June 2022