

# E-Flo<sup>®</sup> SP Supply Systems

3A6331H

EN

***For transferring or dispensing sealants, adhesives, or other medium to high viscosity fluids. For professional use only.***

**Not approved for use in explosive atmospheres or hazardous locations.**

## **D60 3 inch dual post**

20 liter (5 gallon), 30 liter (8 gallon),  
60 liter (16 gallon) sizes  
*150 psi (1.0 MPa, 10 bar) Maximum Air Inlet Pressure*

## **D200 3 inch dual post**

200 liter (55 gallon) size  
*150 psi (1.0 MPa, 10 bar) Maximum Air Inlet Pressure*

## **D200S 6.5 inch dual post**

200 liter (55 gallon) size  
*125 psi (0.9 MPa, 9 bar) Maximum Air Inlet Pressure*

See page 4 for model information, including maximum working pressure and approvals.

*The Graco Control Architecture Electric Components are Listed in Intertek's Directory of Listed Products.*



### **Important Safety Instructions**

Read all warnings and instructions in this manual and in related manuals before using the equipment. Save all instructions.

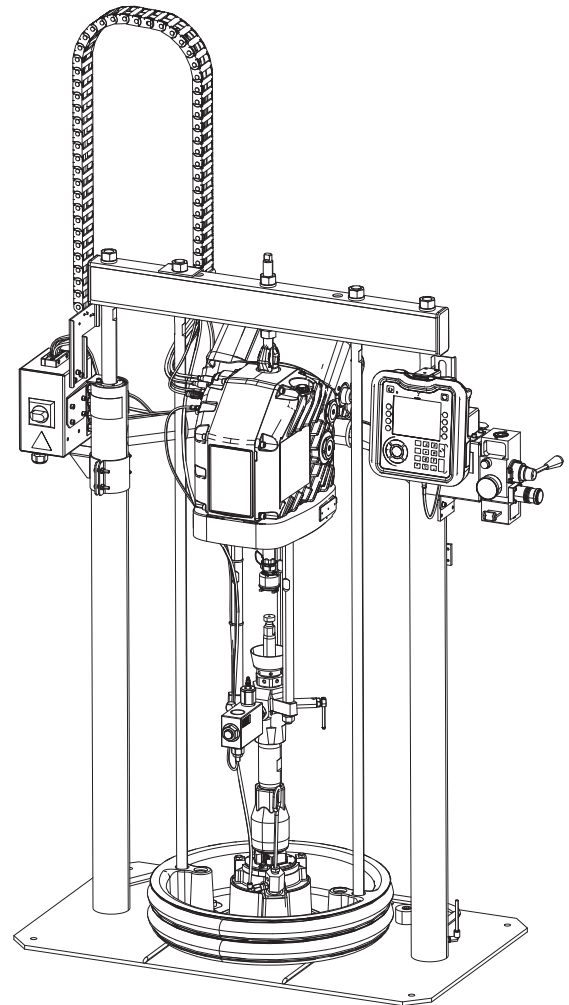

# Contents

<b>Related Manuals</b> .....	<b>3</b>
<b>Models</b> .....	<b>4</b>
System Pressure .....	6
Tandem Ram .....	7
<b>Warnings</b> .....	<b>8</b>
<b>Component Identification</b> .....	<b>11</b>
Typical Installation .....	11
Integrated Air Control Module .....	12
Integrated Air Line Accessories .....	12
Advanced Display Module (ADM) .....	13
Platen Component Identification .....	14
Junction Box Connections .....	15
<b>Installation</b> .....	<b>16</b>
Location .....	16
Grounding .....	16
Power Requirements .....	17
Connect Power .....	17
Attach Drum Stops .....	18
Fluid Hose and Air Line Connections .....	18
Install Vented Oil Cap Before Using Equipment .....	18
<b>Setup</b> .....	<b>19</b>
Wet Cup .....	19
<b>Startup</b> .....	<b>20</b>
Flush the Pump .....	20
Start and Adjust the Ram .....	21
Start and Adjust the Pump .....	21
<b>Pressure Relief Procedure</b> .....	<b>22</b>
<b>Shutdown and Care of the Pump</b> .....	<b>23</b>
Change Drums .....	23
<b>Maintenance</b> .....	<b>24</b>
Driver Maintenance .....	24
Platen Maintenance .....	25
<b>Troubleshooting</b> .....	<b>29</b>
<b>Repair</b> .....	<b>30</b>
Disconnect Pump from Platen .....	30
Connect Platen .....	31
Remove Wipers .....	31
Install Wipers .....	31
Remove Displacement Pump .....	31
Install Displacement Pump .....	32
Remove Driver .....	33
Install Driver .....	34
Supply Unit Repair .....	34

<b>Parts</b> .....	<b>38</b>
D200s 6.5 in. Supply Units .....	38
D200 3 in. Supply Units .....	40
D60 3 in. Supply Units .....	42
D200s and D200 Pump Mounts for 55 Gallon (200 Liter) Platen .....	44
D60 Pump Mount 257624 for 5 Gallon (20 Liter) Platen .....	45
Transformer .....	46
Cable Track .....	48
55 Gallon Platen .....	49
20 Liter (5 Gallon), 30 Liter (8 Gallon), and 60 Liter (16 Gallon) Platens .....	50
<b>Kits and Accessories</b> .....	<b>55</b>
Drum Roller Kits for D200 and D200S Supply Units, 255627 .....	55
Drum Position Clamp Set for D200 Supply Units, 206537 .....	55
Drum Position Clamp for D200S Supply Units ..	55
Enclosed Wet Cup Recirculation Kit .....	55
200 Liter (55 Gallon) Platen Cover Kits, 255691 ..	55
Light Tower Kit, 255468 .....	55
ADM Kit, 25E437 .....	55
CAN Cables .....	55
I/O Cable, 122029 .....	55
Communication Gateway Module (CGM) Kits ..	56
Low Level Sensor Kit, 25E447 .....	58
Tandem Connection Kit, 25E595 .....	59
Tandem Depressurization/Recirculation Kit, 25E618 (carbon steel), 25E619 (stainless steel) ..	60
Tandem Fluid Filter Kit, 25E620 .....	64
<b>Dimensions</b> .....	<b>67</b>
Dimensions .....	68
<b>Pump Performance</b> .....	<b>69</b>
E-Flo SP Performance Charts .....	70
<b>Technical Specifications</b> .....	<b>76</b>
<b>California Proposition 65</b> .....	<b>77</b>
<b>Graco Standard Warranty</b> .....	<b>78</b>
<b>Graco Information</b> .....	<b>78</b>

## Related Manuals

Manual	Description
3A6586	E-Flo SP Electric Pump Instructions - Parts
3A6724	E-Flo SP Software Instructions
313526	Supply Systems Operation
312375	Check-Mate <sup>®</sup> Displacement Pumps Instructions-Parts
311827	Dura-Flo <sup>™</sup> Displacement Pumps (145cc, 180cc, 220cc, 290cc) Instructions-Parts
311825	Dura-Flo <sup>™</sup> Displacement Pumps (430cc, 580cc) Instructions-Parts
311717	Carbon Steel Displacement Pump (1000cc) Instructions-Parts
312889	60 cc Check-Mate Displacement Pump Repair Parts
312467	100 cc Check-Mate Displacement Pump Repair Parts
312468	200 cc Check-Mate Displacement Pump Repair Parts
312469	250 cc Check-Mate Displacement Pump Repair Parts
312470	500 cc Check-Mate Displacement Pump Repair Parts
312374	Air Controls Instructions-Parts
312491	Pump Fluid Purge Kit Instructions - Parts
312492	Drum Roller Kit Instructions
312493	Light Tower Kit Instructions
312494	Enclosed Wetcup Recirculation Kit Instructions - Parts
406681	Platen Cover Kit
334048	EPDM Hose Wiper Kit Instructions - Parts
3A6321	ADM Token In-System Programming Instructions
3A6482	APD20 Advanced Precision Driver Instructions

# Models

Check the identification plate (ID) for the 7-digit part number of the supply system. Use the following matrix to define the construction of the supply system, based on the seven digits. For example, Part No. **EMC1121** represents an electric supply system (**EM**), a carbon steel Check-Mate 100 Severe Duty displacement pump with an electric driver (**C1**), a 3 in. dual post ram with integrated air controls (**1**), a 5-gallon platen with a nitrile seal (**2**), and 240 VAC power (**1**).

## **NOTICE**

To prevent damage to DataTrak soft key buttons, do not press the buttons with sharp objects such as pens, plastic cards, or fingernails.

**NOTE:** Systems with the **EMD** as the first and second digits are Dura-Flo supply systems.

The digits in the matrix on the next page do not correspond to the Ref. Nos. in the Parts drawings and lists.

<b>EM</b>	<b>C1</b>	<b>1</b>				<b>2</b>					<b>1</b>				
<b>First and Second Digit</b>	<b>Third and Fourth Digit</b>	<b>Fifth Digit</b>				<b>Sixth Digit</b>					<b>Seventh Digit</b>				
		<b>Ram Options</b>				<b>Platen and Seal Options</b>					<b>Interface and Power Options</b>				
	<b>Pump Code</b>	<b>Size</b>	<b>Style</b>	<b>Drum Size</b>	<b>Air Controls</b>	<b>Platen Size</b>	<b>Platen Style</b>	<b>Platen Material</b>	<b>Seal Material</b>	<b>Ram Compatibility</b>	<b>Interface</b>	<b>Power</b>			
<b>EM</b> (Electric Supply System)	(See Table 1: for 2-digit Check-Mate Pump Code)	1	3 in.	D60	20 L (5 Gal)	INT	No Platen					1	None	240 VAC	
		2	3 in.	D200	200 L (55 Gal)	INT	2	20 L (5 Gal)	F, SW	CS	Nitrile	D60	2	None	480 VAC
		3	6.5 in.	D200s	200 L (55 Gal)	INT	3	20 L (5 Gal)	F, SW	CS	Polyurethane	D60	3	ADM	240 VAC
							4	20 L (5 Gal)	F, DW	CS	Nitrile	D60	4	ADM	480 VAC
		(See Table 1: for 2-digit Dura-Flo Pump Code)					5	20 L (5 Gal)	F, DW	CS	Polyurethane	D60			
							6	20 L (5 Gal)	F, SW	SS	PTFE coated	D60			
							7	200 L (55 Gal)	DR	PTFE Coated AL	EPDM	D200, D200s			
							8	200 L (55 Gal)	DR	AL	EPDM	D200, D200s			
							9	200 L (55 Gal)	DR	AL	Neoprene	D200, D200s			
							A	200 L (55 Gal)	DR	AL	EPDM Hose	D200, D200s			

KEY:

INT = Integrated air controls      SW = Single wiper      CS = Carbon Steel Severe Duty      CM = Carbon Steel MaxLife®  
 F = Flat      DW = Double wiper      SS = Stainless Steel Severe Duty      SM = Stainless Steel MaxLife  
 DR = Dual o-ring      AL = Aluminum

**Table 1: Pump Code Index**

<b>Pump Code</b>	<b>Part No.</b>	<b>Pump Type</b>	<b>Pump Size</b>	<b>Pump Material</b>
C1	EC100CS1	Check-Mate	100cc	CS
C2	EC100CM1	Check-Mate	100cc	CM
C3	EC100SS1	Check-Mate	100cc	SS
C4	EC100SM1	Check-Mate	100cc	SM
C5	EC200CS1	Check-Mate	200cc	CS
C6	EC200CM1	Check-Mate	200cc	CM
C7	EC200SS1	Check-Mate	200cc	SS
C8	EC200SM1	Check-Mate	200cc	SM
C9	EC250CS1	Check-Mate	250cc	CS
CA	EC250CM1	Check-Mate	250cc	CM
CB	EC250SS1	Check-Mate	250cc	SS
CC	EC250SM1	Check-Mate	250cc	SM
CD	EC500CS1	Check-Mate	500cc	CS
CE	EC500CM1	Check-Mate	500cc	CM
CF	EC500SS1	Check-Mate	500cc	SS

<b>Pump Code</b>	<b>Part No.</b>	<b>Pump Type</b>	<b>Pump Size</b>	<b>Pump Material</b>
CG	EC500SM1	Check-Mate	500cc	SM
D1	ED115CS1	Dura-Flo	115cc	CS
D2	ED145CS1	Dura-Flo	145cc	CS
D3	ED145SS1	Dura-Flo	145cc	SS
D4	ED180CS1	Dura-Flo	180cc	CS
D5	ED180SS1	Dura-Flo	180cc	SS
D6	ED220CS1	Dura-Flo	220cc	CS
D7	ED220SS1	Dura-Flo	220cc	SS
D8	ED290CS1	Dura-Flo	290cc	CS
D9	ED290SS1	Dura-Flo	290cc	SS
DA	ED430CS1	Dura-Flo	430cc	CS
DB	ED430SS1	Dura-Flo	430cc	SS
DC	ED430SM1	Dura-Flo	430cc	SM

**NOTE:** See the E-Flo SP Electric Pump Instructions-Parts manual for a complete parts list.

## System Pressure

Due to factors such as the dispensing system design, the material being pumped, and the flow rate, the dynamic pressure will not reach the rated working (stall) pressure of the system.

	Lower Size	Pump Working (Stall) Pressure			Max Dynamic (Run) Pressure		
		psi	bar	MPa	psi	bar	MPa
Check-Mate	100CS/CM/SS/SM	6,000	414	41.4	6,000	414	41.4
	200CS/CM/SS/SM	4,200	290	29.0	3,905	269	26.9
	250CS/CM/SS/SM	3,400	234	23.4	3,122	215	21.5
	500CS/CM/SS/SM	1,600	110	11.0	1,487	103	10.3
Dura-Flow	145SS	5,600	386	38.6	5,204	359	35.9
	180SS	4,500	310	31.0	4,164	287	28.7
	220SS	3,700	255	25.5	3,470	239	23.9
	290SS	2,800	193	19.3	2,602	179	17.9
	430CS/SS/SM	1,900	131	13.1	1,735	120	12.0
	115CS	6,000	414	41.4	6,000	414	41.4
	145CS	5,600	386	38.6	5,204	359	35.9
	180CS	4,500	310	31.0	4,164	287	28.7
	220CS	3,700	255	25.5	3,472	239	23.9
	290CS	2,800	193	19.3	2,602	179	17.9

## Flow Rate Table

	Lower Size	Flow Rate (cc/min)	Flow Rate (gpm)	Outlet Fitting Size
Check-Mate	100CS/CM/SS/SM	2,500	0.66	1 in. NPT female
	200CS/CM/SS/SM	5,000	1.32	1 in. NPT female
	250CS/CM/SS/SM	6,250	1.65	1 in. NPT female
	500CS/CM/SS/SM	12,500	3.30	1-1/2 in. NPT female
Dura-Flow	145SS	3,625	0.96	1 in. NPT female
	180SS	4,500	1.19	1 in. NPT female
	220SS	5,500	1.45	1 in. NPT female
	290SS	7,250	1.92	1 in. NPT female
	430CS/SS/SM	10,750	2.84	1-1/2 in. NPT female
	115CS	2,875	0.76	1 in. NPT female
	145CS	3,625	0.96	1 in. NPT female
	180CS	4,500	1.19	1 in. NPT female
	220CS	5,500	1.45	1 in. NPT female
	290CS	7,250	1.92	1 in. NPT female

## Tandem Ram

### How to Buy

1. Configure Tandem Ram “A” - E-Flo SP Ram with an ADM (Quantity 1 per Tandem System).
  - Example: **EMC1283** – D200 Ram, Electric Pump with Check-Mate 100 CS Lower, 200L EPDM Platen, 240V, with ADM.
2. Configure Tandem Ram “B” - E-Flo SP Ram without an ADM (Quantity 1 per Tandem System).
  - Example: **EMC1281** – D200 Ram, Electric Pump with Check-Mate 100 CS Lower, 200L EPDM Platen, 240V, without ADM.
3. Purchase Tandem Connection Kit, **25E595** (Quantity 1 per Tandem System).
4. Purchase Accessories.
  - Depressurization/Recirculation Kit (Quantity 1 per Ram)
    - 25E618**: for Carbon Steel Pump Lowers
    - 25E619**: for Stainless Steel Pump Lowers
  - Fluid Filter Kit, **25E620** (Quantity 1 per Tandem System)
  - Extension Cables for Fluid Filter Monitoring Pressure Transducers (Quantity 1 per Ram)
    - 124943**: 1 meter
    - 122497**: 2 meters
    - 124409**: 3 meters
    - 17H363**: 7.5 meters
    - 17H364**: 16 meters
  - Low Level Sensor Kit, **25E447** (Quantity 1 per Ram)

**NOTE:** Rams come with Empty Level Sensors already installed.

5. Purchase hoses for the system.

- For Check-Mate Pumps:

Pump Lower Size	Max. Pressure Rating
100cc	6000 psi
200cc	4200 psi
250cc	3400 psi
500cc	1600 psi

- For Dura-Flo Pumps:

Pump Lower Size	Max. Pressure Rating
115cc	6000 psi
145cc	5600 psi
180cc	4500 psi
220cc	3700 psi
290cc	2800 psi
430cc	1900 psi





# Warnings



The following warnings are for the setup, use, grounding, maintenance, and repair of this equipment. The exclamation point symbol alerts you to a general warning and the hazard symbols refer to procedure-specific risks. When these symbols appear in the body of this manual or on warning labels, refer back to these Warnings. Product-specific hazard symbols and warnings not covered in this section may appear throughout the body of this manual where applicable.

## DANGER

	<p><b>SEVERE ELECTRIC SHOCK HAZARD</b></p> <p>This equipment can be powered by more than 240 V. Contact with this voltage will cause death or serious injury.</p> <ul style="list-style-type: none"> <li>Turn off and disconnect power at main switch before disconnecting any cables and before servicing equipment.</li> <li>This equipment must be grounded. Connect only to grounded power source.</li> <li>All electrical wiring must be done by a qualified electrician and comply with all local codes and regulations.</li> </ul>
---	---

## WARNING

    	<p><b>SKIN INJECTION HAZARD</b></p> <p>High-pressure fluid from dispensing device, hose leaks, or ruptured components will pierce skin. This may look like just a cut, but it is a serious injury that can result in amputation. <b>Get immediate surgical treatment.</b></p> <ul style="list-style-type: none"> <li>Do not point dispensing device at anyone or at any part of the body.</li> <li>Do not put your hand over the fluid outlet.</li> <li>Do not stop or deflect leaks with your hand, body, glove, or rag.</li> <li>Follow the <b>Pressure Relief Procedure</b> when you stop dispensing and before cleaning, checking, or servicing equipment.</li> <li>Tighten all fluid connections before operating the equipment.</li> <li>Check hoses and couplings daily. Replace worn or damaged parts immediately.</li> </ul>
---	---

 	<p><b>MOVING PARTS HAZARD</b></p> <p>Moving parts can pinch, cut or amputate fingers and other body parts.</p> <ul style="list-style-type: none"> <li>Keep clear of moving parts.</li> <li>Do not operate equipment with protective guards or covers removed.</li> <li>Equipment can start without warning. Before checking, moving, or servicing equipment, follow the <b>Pressure Relief Procedure</b> and disconnect all power sources.</li> </ul>
--	---



# ! WARNING



## FIRE AND EXPLOSION HAZARD

Flammable fumes, such as solvent and paint fumes, in **work area** can ignite or explode. Paint or solvent flowing through the equipment can cause static sparking. To help prevent fire and explosion:



- Use equipment only in well-ventilated area.
- Eliminate all ignition sources; such as pilot lights, cigarettes, portable electric lamps, and plastic drop cloths (potential static sparking).
- Ground all equipment in the work area. See **Grounding** instructions.
- Never spray or flush solvent at high pressure.
- Keep work area free of debris, including solvent, rags and gasoline.
- Do not plug or unplug power cords, or turn power or light switches on or off when flammable fumes are present.
- Use only grounded hoses.
- Hold gun firmly to side of grounded pail when triggering into pail. Do not use pail liners unless they are anti-static or conductive.
- **Stop operation immediately** if static sparking occurs or you feel a shock. Do not use equipment until you identify and correct the problem.
- Keep a working fire extinguisher in the work area.



## EQUIPMENT MISUSE HAZARD

Misuse can cause death or serious injury.



- Do not operate the unit when fatigued or under the influence of drugs or alcohol.
- Do not exceed the maximum working pressure or temperature rating of the lowest rated system component. See **Technical Specifications** in all equipment manuals.
- Use fluids and solvents that are compatible with equipment wetted parts. See **Technical Specifications** in all equipment manuals. Read fluid and solvent manufacturer's warnings. For complete information about your material, request Safety Data Sheets (SDSs) from distributor or retailer.
- Turn off all equipment and follow the **Pressure Relief Procedure** when equipment is not in use.
- Check equipment daily. Repair or replace worn or damaged parts immediately with genuine manufacturer's replacement parts only.
- Do not alter or modify equipment. Alterations or modifications may void agency approvals and create safety hazards.
- Make sure all equipment is rated and approved for the environment in which you are using it.
- Use equipment only for its intended purpose. Call your distributor for information.
- Route hoses and cables away from traffic areas, sharp edges, moving parts, and hot surfaces.
- Do not kink or over bend hoses or use hoses to pull equipment.
- Keep children and animals away from work area.
- Comply with all applicable safety regulations.



## SPLATTER HAZARD

Hot or toxic fluid can cause serious injury if splashed in the eyes or on skin. During blow off of platen, splatter may occur.

- Use minimum air pressure when removing platen from drum.

# WARNING



## **TOXIC FLUID OR FUMES HAZARD**

Toxic fluids or fumes can cause serious injury or death if splashed in the eyes or on skin, inhaled, or swallowed.

- Read Safety Data Sheets (SDSs) to know the specific hazards of the fluids you are using.
- Store hazardous fluid in approved containers, and dispose of it according to applicable guidelines.



## **PERSONAL PROTECTIVE EQUIPMENT**

Wear appropriate protective equipment when in the work area to help prevent serious injury, including eye injury, hearing loss, inhalation of toxic fumes, and burns. Protective equipment includes but is not limited to:

- Protective eyewear, and hearing protection.
- Respirators, protective clothing, and gloves as recommended by the fluid and solvent manufacturer.

# Component Identification

## Typical Installation

D200 3 in. and D200s 6.5 in. Dual Post

**NOTICE**

Always lift the supply system at the proper lift locations (see FIG. 1). Do **not** lift in any other way. Failure to lift at the proper lift locations can result in damage to the supply system.

EMC1223 Model Shown

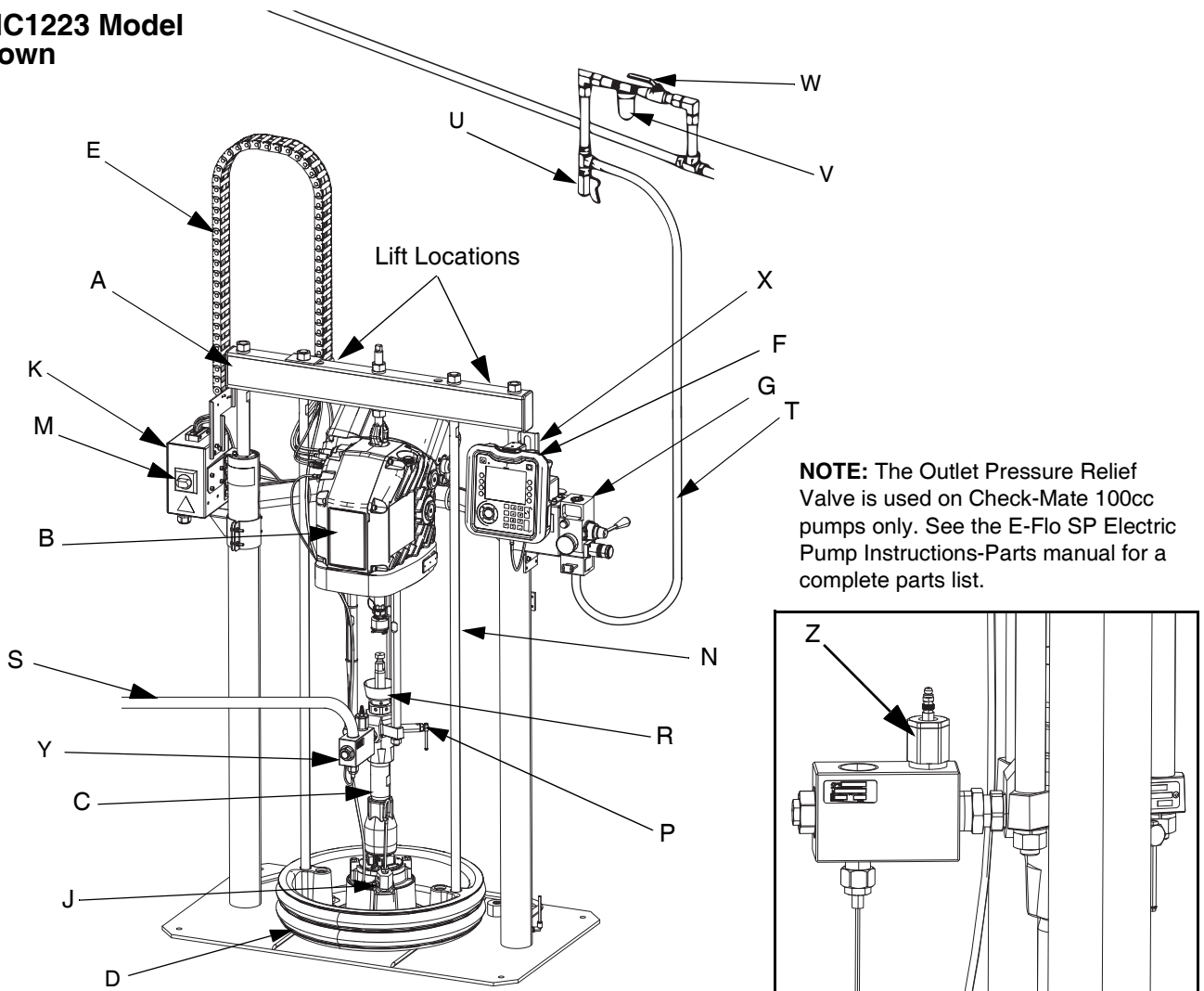

FIG. 1: Typical Installation

**Key:**

- |  |  |
|--|--|
| <ul style="list-style-type: none"> <li>A Ram Assembly</li> <li>B Electric Driver</li> <li>C Displacement Pump</li> <li>D Platen</li> <li>E Cable Track</li> <li>F Advanced Display Module (ADM)</li> <li>G Integrated Air Controls (see FIG. 2)</li> <li>J Platen Bleed Port</li> <li>K Power Junction Box</li> <li>M Disconnect Switch</li> </ul> | <ul style="list-style-type: none"> <li>N Platen Lift Rod</li> <li>P Pump Bleed Valve</li> <li>R Enclosed Wet Cup</li> <li>S Fluid Line (not supplied)</li> <li>T Air Line (not supplied)</li> <li>U Air Line Drain Valve (not supplied)</li> <li>V Air Filter (not supplied)</li> <li>W Bleed Type Air Shutoff Valve (required) (not supplied)</li> <li>X Level Sensors</li> <li>Y Outlet Pressure Transducer</li> <li>Z Outlet Pressure Relief Valve (Check-Mate 100 only)</li> </ul> |
|--|--|

## Integrated Air Control Module

D200, D200s, and D60 Models

The integrated air controls include:

- **Main air slider valve (AA):** turns air on and off to the system. When closed, the valve relieves pressure downstream.
- **Ram air regulator (AB):** controls ram up and down pressure and blowoff pressure.
- **Ram director valve (AC):** controls ram direction.
- **Exhaust port with muffler (AD)**
- **Blowoff button (AE):** turns air on and off to push the platen out of an empty drum.

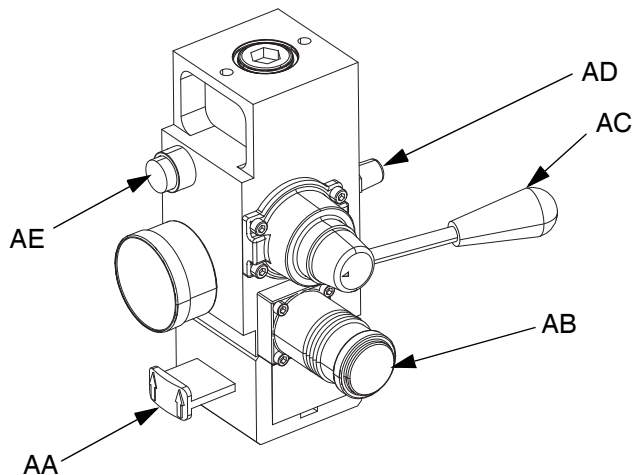

FIG. 2. Integrated Air Control Module

## Integrated Air Line Accessories

See FIG. 1.

- **Air line drain valve (U).**
- **Air line filter (V):** removes harmful dirt and moisture from compressed air supply.
- **Second bleed-type air valve (W) (required):** isolates air line accessories for servicing. Locate upstream from all other air line accessories.
- **Air relief valve (required) (not visible):** automatically relieves excessive pressure.

# Advanced Display Module (ADM)

## Front and Rear Views

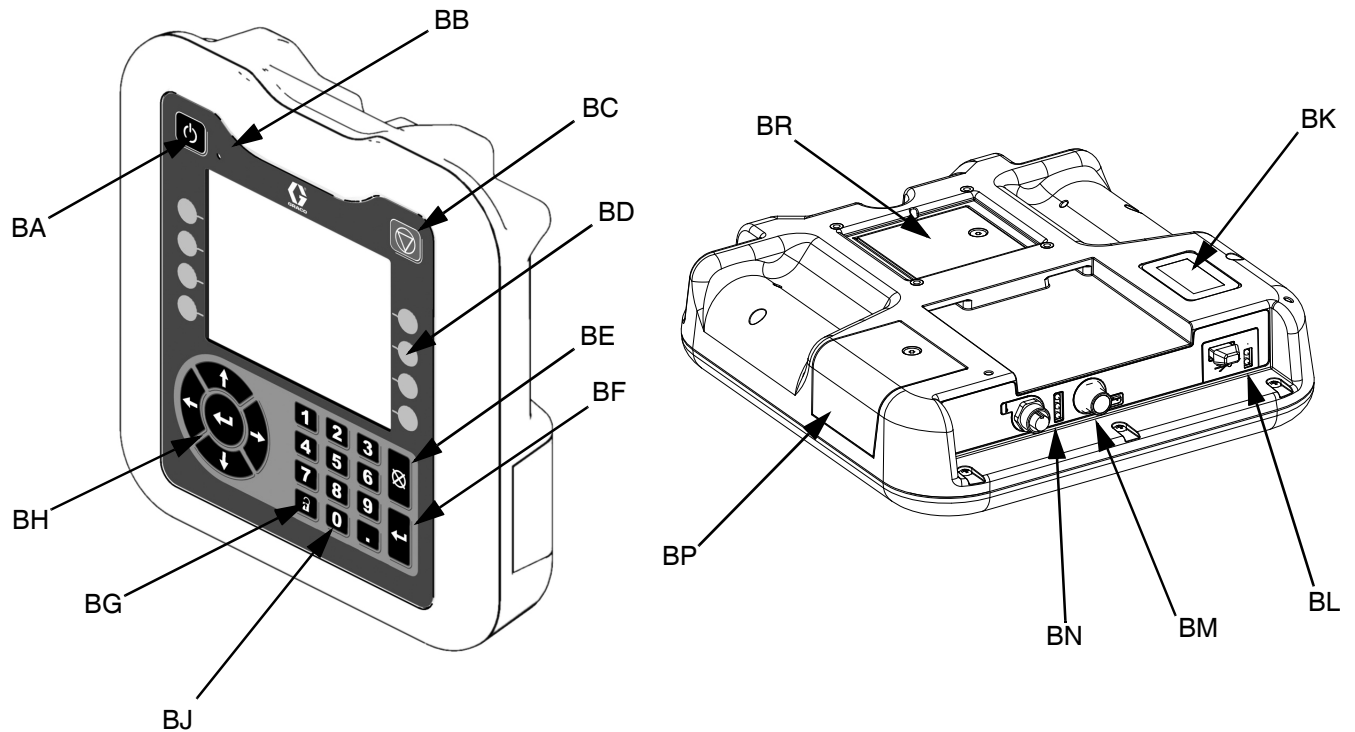

**FIG. 3: ADM Component Identification**

### Key:

#### **BA Pump Enable**

Enables the pump. Toggles between Active and System Off.

#### **BB Pump Status Indicator Light**

#### **BC Pump Soft Stop**

Stops all pump processes and disables the pump.

#### **BD Soft Keys**

Defined by the icon on the screen next to the soft key.

#### **BE Cancel**

Cancel a selection or number entry while in the process of entering a number or making a selection. Cancels the pump processes.

#### **BF Enter**

Accept change, acknowledge error, select item, and toggle selected item.

#### **BG Lock/Setup**

Toggle between run and setup screens.

#### **BH Directional Keypad**

Navigate within a screen or to a new screen.

#### **BJ Numeric Keypad**

#### **BK Part Number Identification Label**

#### **BL USB Interface**

#### **BM CAN Cable Connection**

Power and communication.

#### **BN Module Status LEDs**

Visual indicators to show the status of the ADM.

#### **BP Token Access Cover**

Access cover for software token.

#### **BR Battery Access Cover**

## Platen Component Identification

Model 255319, 200 liter (55 gallon)

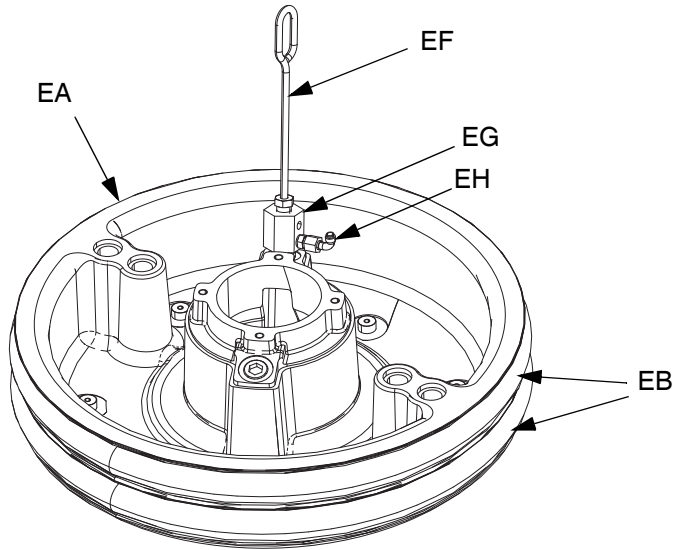

Model 256742 and 256745,  
20 liter (5 gallon)

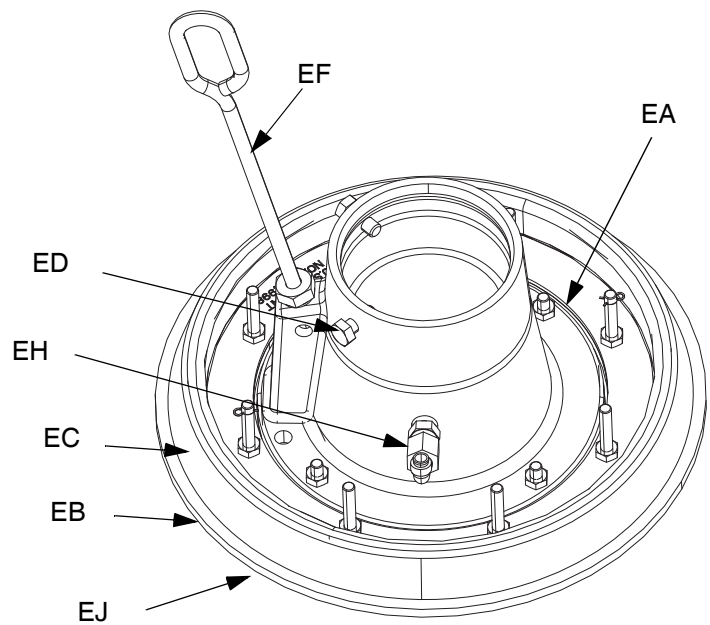
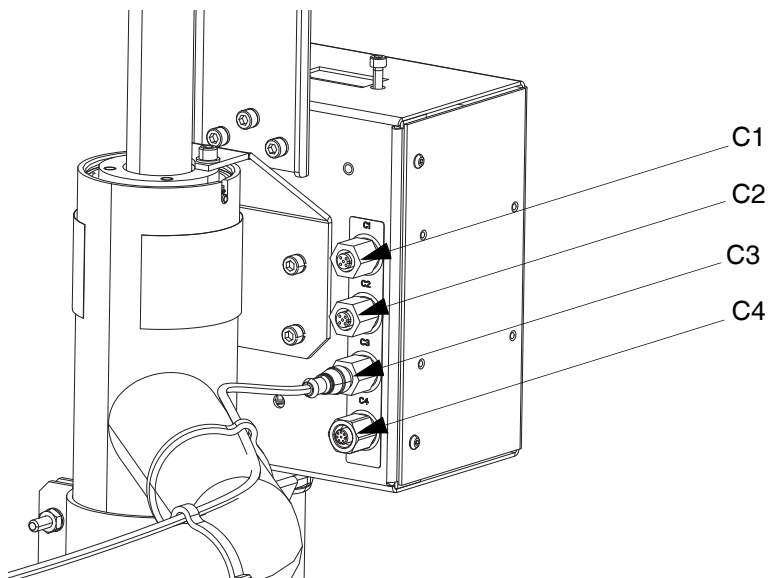

FIG. 4

**Key:**

- EA Plate
- EB Wipers
- EC Spacer
- ED Cap Screws
- EE Clamps (not shown)
- EF Bleed Stick
- EG Bleed Port
- EH Air Assist Body Check Valve
- EJ Wiper Plate (under wiper)
- EK O-ring Seal (not shown)

## Junction Box Connections





**FIG. 5**

**Key:**

- C1 CGA CAN Port
- C2 GCA CAN Port
- C3 Low and Empty Level Sensor Input
- C4 Fluid Filter Solenoid Input

**NOTE:** See the E-Flo SP Software Instructions manual for all I/O descriptions.

## Installation

				
All electrical wiring must be done by a qualified electrician and comply with all local codes and regulations.				

## Location

To properly locate and anchor the supply system, refer to **Dimensions** on page 67.

<b>NOTICE</b>
Always lift the supply system at the proper lift locations (see FIG. 1). Do <b>not</b> lift in any other way. Failure to lift at the proper lift locations can result in damage to the supply system.

Attach a lifting sling at the proper lift locations. Lift off the pallet using a crane or a forklift.





**NOTE:** The lift ring on the driver is only to be used for replacing the driver. Do not use it to lift the entire system.

Position the ram so the driver, disconnect switch, air controls, and ADM are easily accessible. Ensure that there is enough space overhead for the ram to raise fully.

Using the holes in the ram base as a guide, drill holes for 1/2 in. (13 mm) anchors.

Ensure that the ram base is level in all directions. If necessary, level the base using metal shims. Secure the base to the floor using 1/2 in. (13 mm) anchors that are long enough to prevent the ram from tipping.

## Grounding

				
The equipment must be grounded to reduce the risk of static sparking and electric shock. Electric or static sparking can cause fumes to ignite or explode. Improper grounding can cause electric shock. Grounding provides an escape wire for the electric current.				

**Electric pump:** the pump is grounded through the power cord.

**Ram:** the ram is grounded through the power cord.

**Air and fluid hoses:** use only electrically conductive hoses with a maximum of 500 ft. (150 m) combined hose length to ensure grounding continuity. Check the electrical resistance of the hoses. If the total resistance to ground exceeds 29 megaohms, replace the hose immediately.

**Air compressor:** follow manufacturer's recommendations.

**Dispense valve:** ground through connection to a properly grounded fluid hose and pump.

**Fluid supply container:** follow local code.

**Solvent pails used when flushing:** follow local code. Use only conductive metal pails, placed on a grounded surface. Do not place the pail on a non-conductive surface, such as paper or cardboard, which interrupts the grounding continuity.

**To maintain grounding continuity when flushing or relieving pressure:** hold a metal part of the dispense valve firmly to the side of a grounded metal pail, then trigger the valve.



## Power Requirements

The system requires a dedicated circuit protected with a circuit breaker.

Voltage	Phase	Hz	Current
200-240 VAC	1	50/60	20 A
400-480 VAC	1	50/60	10 A

## Connect Power

### NOTICE

To avoid equipment damage, route and secure a power cord that is long enough to allow the full range of movement for the ram.

- Cut power cord wires to the following lengths:
  - Ground wire - 6.5 inches (16.5 cm)
  - Power wires - 3.0 inches (7.6 cm)
  - Add ferrules as necessary. See FIG. 6.

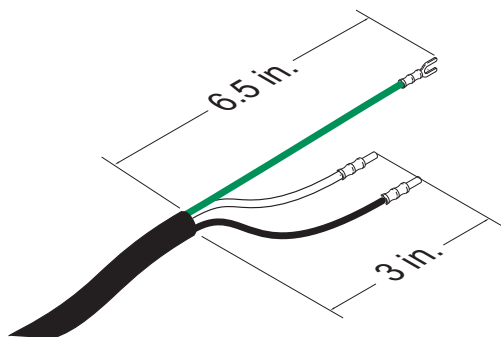

**FIG. 6: Power Cord**

- Remove the six screws holding the cover of the junction box (K), then remove the junction box cover.

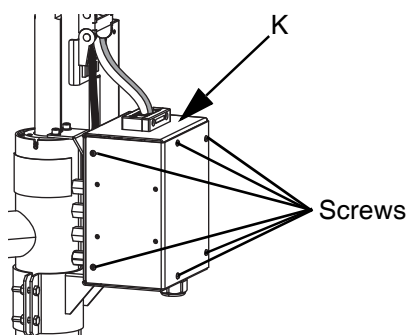

**FIG. 7: Remove the Junction Box Cover**

- Insert the power cord through the cord grip and into the junction box (K).

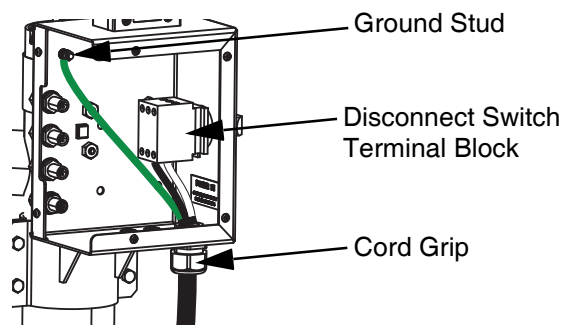

**FIG. 8: Power Connection**

- Attach the ground wire to the ground stud inside the junction box (K).
- Refer to FIG. 9 and connect the wires from the power cord into terminals 4T2 and 6T3 on the disconnect switch terminal block.

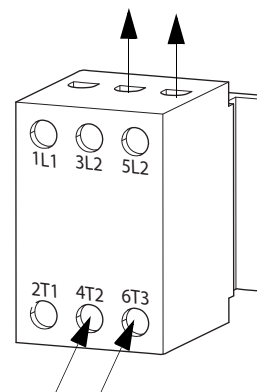
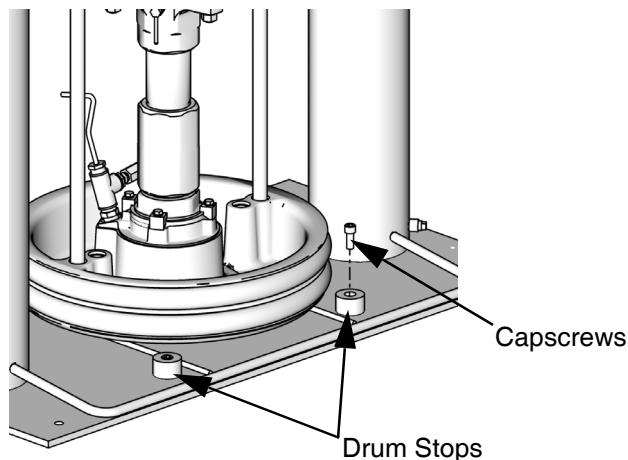

**FIG. 9: Disconnect Switch Terminal Block**

- Tighten the cord grip to securely hold the power cord to the junction box (K).
- Replace the junction box cover and secure it with the six screws that were removed in step 2.

## Attach Drum Stops

The electric supply systems are shipped with drum stops in place to help position the drum on the ram. For replacement parts, order Kit 255477. The kit includes 2 each of capscrews, lock washers (not shown), and drum stops.



**FIG. 10: Drum Stop Installation**

1. Locate the correct set of mounting holes on the ram base.
2. Using the capscrews and lock washers, attach the drum stops to the ram base.

## Fluid Hose and Air Line Connections

Refer to FIG. 1 on page 11 for a typical installation.

Attach the fluid hose (not supplied) to the Outlet Check Valve (E) connection.

Attach the air line (not supplied) to the bottom of the Integrated Air Control (G) at the 3/4 in. NPT connection.

**NOTE:** Be sure all components are adequately sized and pressure rated to meet the system's requirements.

## Install Vented Oil Cap Before Using Equipment.

The driver gear-box is shipped from the factory pre-filled with oil. The temporary unvented cap prevents oil leaks during shipment. This temporary cap must be replaced with the vented oil cap supplied with the equipment, before use.

**NOTE:** Prior to use, check oil level. Oil level should be half way up the sight glass.

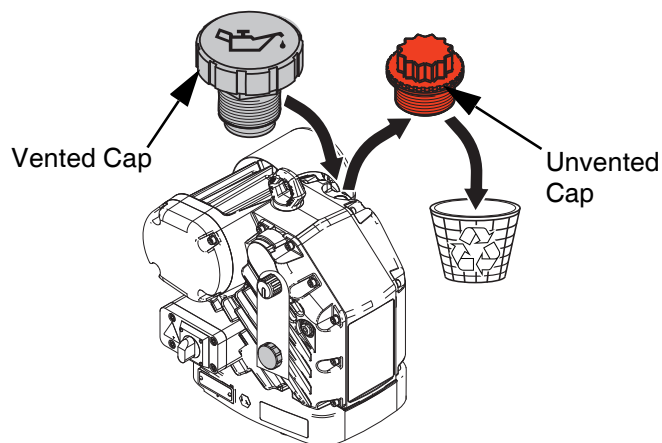

**FIG. 11: Unvented and Vented Oil Caps**

# Setup

## Wet Cup



Before starting, fill the wet cup (L) 1/3 full with Graco Throat Seal Liquid (TSL) or a compatible solvent.

### Torque the Wet Cup

The wet cup is torqued at the factory; however, throat packing seals on Severe Duty pumps may relax over time. Check wet cup torque frequently after initial start-up and periodically after the first week of production. Maintaining proper wet cup torque is important to extending seal life.

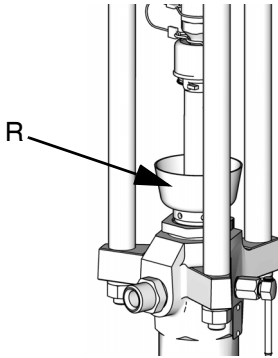

**FIG. 12: Wet Cup**

**NOTE:** MaxLife pumps use a special u-cup throat seal that is non-adjustable and does not require periodic torquing.

1. Follow the **Pressure Relief Procedure** on page 22.
2. Torque the wet cup (R) 95-115 ft-lbs (128-155 N•m) using the packing nut wrench (supplied) whenever necessary. Do not overtighten the wet cup. See the table below for torque values.

# Startup

Letters in parenthesis are used in this section for reference to callouts in the **Component Identification** section starting on page 11.

## Flush the Pump

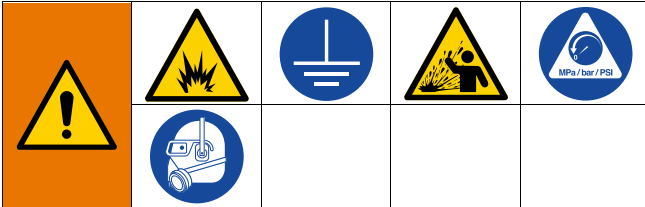

To avoid fire and explosion, always ground the equipment and the waste container. To avoid static sparking and injury from splashing, always flush at the lowest possible pressure.

**NOTE:** The pump is tested with lightweight oil, which is left in to protect the pump parts. If the fluid you are using may be contaminated by the oil, flush it out with a compatible solvent before using the pump.





Always flush at the lowest pressure possible. Check connectors for leaks and tighten as necessary. Flush with a fluid that is compatible with the fluid being dispensed and the equipment wetted parts.

**NOTE:** Check with your fluid manufacturer or supplier for recommended flushing fluids and flushing frequency.

### NOTICE

To prevent damage to the pump from rust, never leave water or water-based fluid in a carbon steel pump overnight. If you are pumping a water-based fluid, flush with water first. Then flush with a rust inhibitor, such as mineral spirits. Relieve pressure, but leave the rust inhibitor in the pump to protect parts from corrosion.

**NOTE:** Refer to the E-Flo SP Software Instructions manual for additional information about using the software features of the ADM. See **Related Manuals** on page 3.

1. Follow the **Pressure Relief Procedure** on page 22.
  2. Place a pail of compatible solvent in the ram. See **Grounding** instructions for solvent pails on page 16.
  3. Turn the disconnect switch (M) ON.
  4. At the ADM (F), use the ADM's arrow keys to select the pump you want to flush from the Menu Bar.
- NOTE:** If multiple pumps are connected together, there can be up to six pumps listed in the Menu Bar.
5. Enter the Edit screen for that pump by pressing the soft key next to the  icon.
  6. Press the soft key next to the Pressure Mode  icon.
  7. Enter 100 psi (0.69 MPa, 6.9 bar) as the pressure.
  8. Press the soft key next to the Pump On/Off  icon to turn on the pump.
  9. Adjust pressure as necessary.
  10. Hold a metal part of the dispense valve firmly to the side of a grounded metal pail.
  11. Open the dispense valve and flush the system until clear solvent flows from the gun/valve.
  12. Exit the Edit screen by pressing the soft key next to the  icon.
  13. Repeat steps 3 through 11 for each pump you want to flush.
  14. Follow the **Pressure Relief Procedure** on page 22.
  15. Remove the solvent pail from the ram.

## Start and Adjust the Ram



1. Turn the disconnect switch (M) OFF.
2. Raise the Ram by opening the main air slider valve (AA) and setting the ram air regulator (AB) to 40 psi (0.28 MPa, 2.8 bar).
3. Set the ram director valve handle (AC) to UP and let the ram rise to its full height.
4. Set the ram director valve handle (AC) to neutral.
5. Lubricate the platen wiper (EB) with grease or other lubricant compatible with the fluid you will pump.
6. Put a full drum/pail on the ram base and center it under the platen (D).
7. Remove the drum/pail cover and smooth the surface of the fluid with a straightedge. To prevent air from being trapped under the platen, scoop fluid from the center of the pail to the sides, to make the surface concave.
8. Adjust the drum/pail to be sure it is aligned with the platen, and remove the platen bleed stick to open the platen bleed port.
9. With hands away from the drum/pail and the platen, push down on the ram director valve (AC) handle, and lower the ram until the platen rests on the lip of the drum/pail. Move the ram director valve handle to the horizontal position (neutral).
10. Lower the ram:
  - a. Set the ram director valve (AC) to DOWN and continue to lower the ram until fluid appears at the platen bleed port.
  - b. Set the ram director valve to neutral, replace the platen bleed stick, and tighten it securely.

## Start and Adjust the Pump



1. With the disconnect switch (M) OFF, set the ram air regulator (AB) to about 50 psi (0.35 MPa, 3.5 bar). Set the ram director valve (AC) to DOWN.
2. Turn the driver disconnect switch (M) ON.
3. Start the pump. See the E-Flo SP Software Instructions manual for instructions on operating the system.
4. Keep the ram director valve (AC) set to DOWN while the pump is operating.

**NOTE:** Increase air pressure to the ram if the pump does not prime properly with more viscous fluids. Decrease air pressure if fluid is forced out around the top seal or platen.

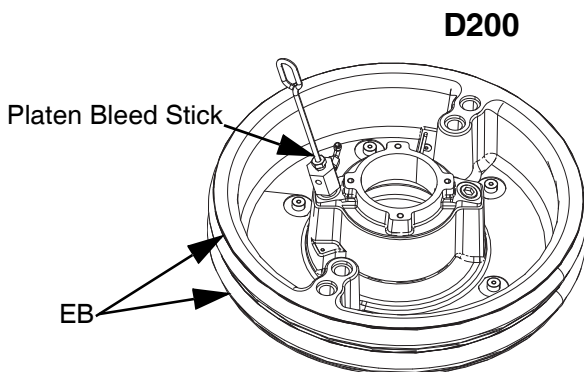
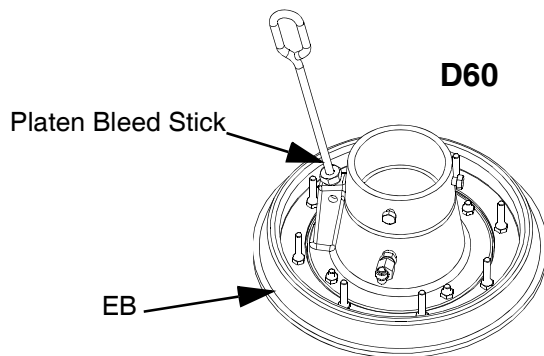

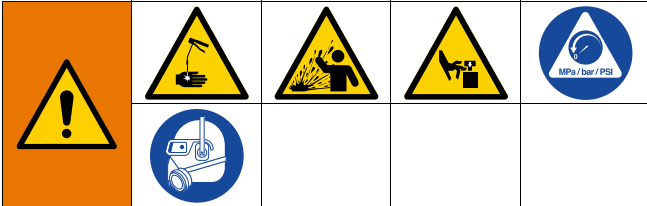

# Pressure Relief Procedure

 Follow the Pressure Relief Procedure whenever you see this symbol.



This equipment stays pressurized until pressure is manually relieved. To help prevent serious injury from pressurized fluid, such as skin injection, splashing fluid and moving parts, follow the Pressure Relief Procedure when you stop spraying and before cleaning, checking, or servicing the equipment.

7. Hold a metal part of the dispense valve firmly to the side of a grounded metal pail, and open the dispense valve to relieve pressure.
8. Open your system's fluid line drain valve and open the pump bleed valve (P). Have a container ready to catch the drainage.
9. Leave the pump bleed valve (P) open until ready to dispense again.

1. At the ADM, enter manual mode by pressing the soft key next to the  icon.
2. Press the soft key next to the  icon to stop the pump.
3. Turn the disconnect switch (M) OFF.

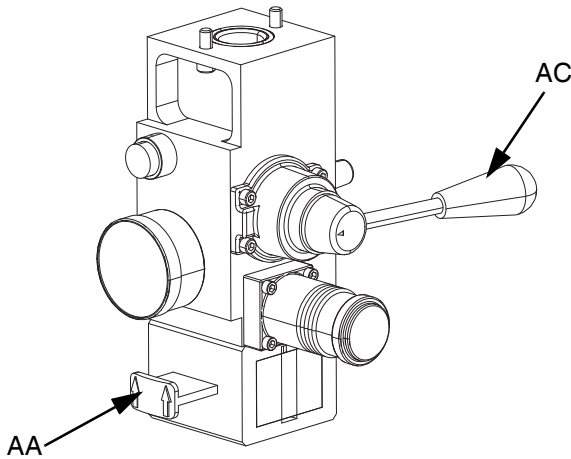

**FIG. 13: Air Control for Pressure Relief**

4. Close the main air slider valve (AA).
5. Set the ram director valve (AC) to DOWN. The ram will slowly drop.
6. Once the ram is completely down, jog the ram director valve up and down to bleed air from the ram cylinders.

# Shutdown and Care of the Pump



## NOTICE

To prevent damage to the pump from rust, never leave water or water-based fluid in a carbon steel pump overnight. If you are pumping a water-based fluid, flush with water first. Then flush with a rust inhibitor, such as mineral spirits. Relieve pressure, but leave the rust inhibitor in the pump to protect parts from corrosion.

1. Set the ram director valve (AC) to DOWN, and lower the ram to the desired position for shutdown.
2. Set the ram director valve (AC) to neutral.
3. Stop the pump at the bottom of the stroke to prevent fluid from drying on the exposed displacement rod and damaging the throat packings. See the E-Flo SP Software Instructions manual for information about jogging the pump. See **Related Manuals** on page 3.
4. Always flush the pump before the fluid dries on the displacement rod. Follow steps to **Flush the Pump** on page 20.

## Change Drums

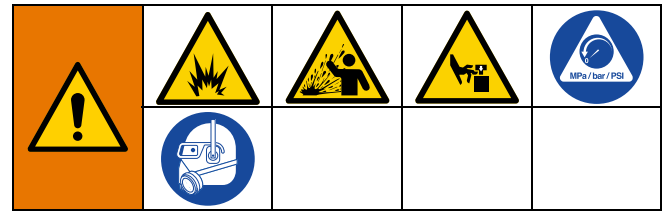

1. Stop the pump.
2. Set the ram director valve (AC) to UP to raise the platen, and immediately press and hold the blowoff air button (AE) until the platen is completely out of the drum. Use the minimum amount of air pressure necessary to push the platen out of the drum.



Excessive air pressure in the material drum could cause the drum to rupture, causing serious injury. The platen must be free to move out of the drum. Never use drum blowoff air with a damaged drum.

3. Release the blowoff air button (AE) and allow the ram to rise to its full height.
4. Remove the empty drum.
5. Inspect the platen and, if necessary, remove any remaining material or material build-up.

# Maintenance

## Driver Maintenance



### NOTICE

Do not open/remove the gear cover. The gear side is not intended to be serviced. Opening the gear cover may alter the factory set bearing pre-load and may reduce the product life.

### Preventative Maintenance Schedule

The operating conditions of your particular system determine how often maintenance is required. Establish a preventative maintenance schedule by recording when and what kind of maintenance is needed, and then determine a regular schedule for checking your system.

### Change the Oil

**NOTE:** Change the oil after a break-in period of 200,000 to 300,000 cycles. After the break-in period, change the oil once per year.

1. Follow the **Pressure Relief Procedure** on page 22.
2. Place a minimum 2 quart (1.9 liter) container under the oil drain port.
3. Remove the oil drain plug. See FIG. 14 for the location of the drain plug. Allow all oil to drain from the driver.
4. Reinstall the oil drain plug. Torque to 18-23 ft-lb (25-30 N•m).
5. Open the fill cap and add Graco Part 16W645 ISO 220 silicone-free synthetic EP gear oil. Check the oil level in the sight glass. Fill until the oil level is near the halfway point of the sight glass. The oil capacity is approximately 1.0 - 1.2 quarts (0.9 - 1.1 liters). **Do not overfill.**
6. Reinstall the fill cap.

### Check Oil Level

Refer to FIG. 14 below. Check the oil level in the sight glass on a regular basis. The oil level should be near the halfway point of the sight glass when the driver is not running. If the oil is low, open the fill cap and add Graco Part No. 16W645 ISO 220 silicone-free synthetic EP gear oil.

The oil capacity is approximately 1.0 - 1.2 quarts (0.9 - 1.1 liters). **Do not overfill.**

### NOTICE

Only use oil with Graco part number 16W645. Any other oil may not lubricate properly and can cause damage to the drive train.

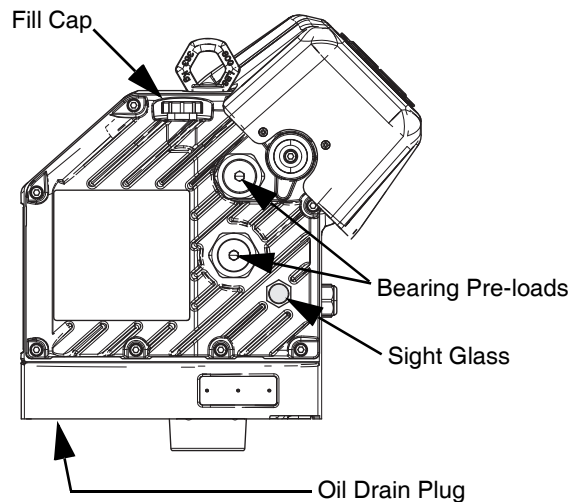

**FIG. 14: Sight Glass and Oil Fill Cap**

### Bearing Pre-Load

The bearing pre-loads are factory set and are not user adjustable. Do not adjust the bearing pre-loads. See APD20 Advanced Precision Driver Instructions-Parts manual for maintenance information.



## Platen Maintenance



See FIG. 15. If the platen does not come out of the pail easily when the pump is being raised, the air assist tube (F) or check valve may be plugged. A plugged valve prevents air from reaching the underside of the plate to assist in raising it from the pail.

1. Follow the **Pressure Relief Procedure** on page 22.
2. Refer to parts illustration on page 50 and disassemble air assist valve as shown.
3. Clear air assist tube (AT) in platen. Clean all parts of valve and reassemble.
4. Remove bleed stick (EF) from platen. Push bleed stick through bleed relieve ports to remove material residue.

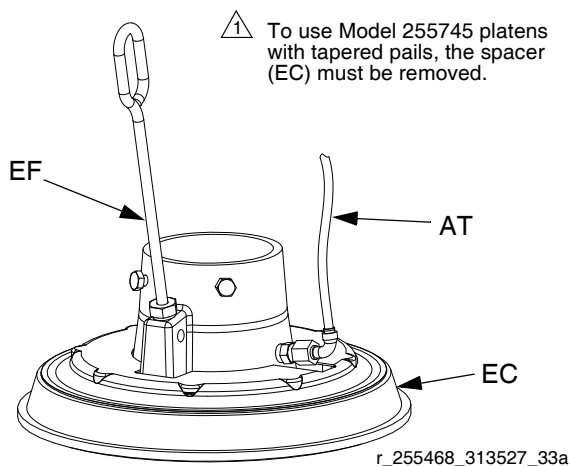

**FIG. 15**

## Adjust Spacers

### Tapered and Straight Sided Pails

The platen is supplied for use with 20 liter (5 gallon), 30 liter (8 gallon), and 60 liter (16 gallon) straight sided pails, but only single wiper platens can be easily modified for use with tapered pails.

### Platen with Tapered Pails

1. Follow the **Pressure Relief Procedure** on page 22.
2. *Working from the bottom*, use screwdriver to pry spacer (EC) loose. Work spacer upward completely above the flange of the platen. See FIG. 16.
3. By hand, angle spacer (EC) and work it off the plate, pulling it down over the flange and bottom wipers (EB). See FIG. 17.
4. Save spacer (EC), as it is required for other applications.

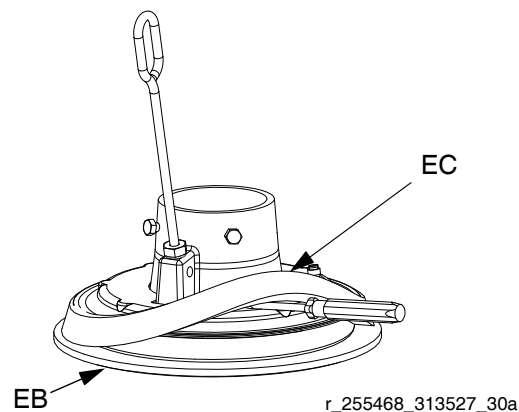

**FIG. 16**

### Platen with straight sided pail

1. Follow the **Pressure Relief Procedure** on page 22.
2. Ensure large diameter of spacer (EC) is facing **down**. Work spacer (EC) up over the platen by hand completely above the flange of the platen. See FIG. 17.
3. *Working from the top*, use screwdriver to position spacer (EC) between flange and wipers (EB). See FIG. 18.

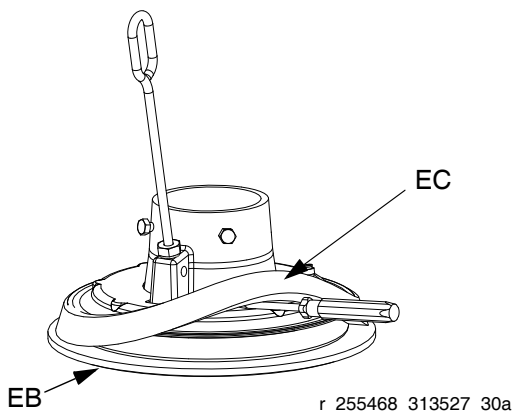

**FIG. 17: Sliding spacer**

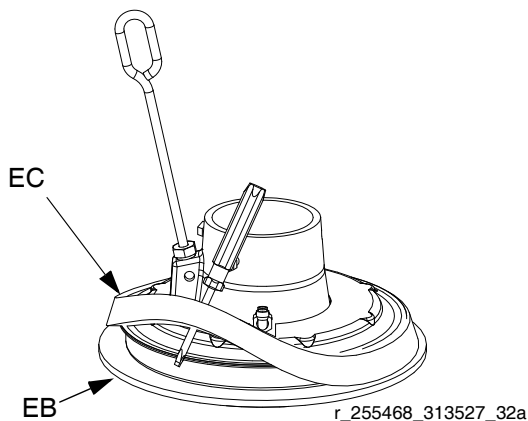

**FIG. 18: Installing Spacer**

### Remove and Reinstall Wipers

#### Disassemble 20, 30, and 60 Liter Wiper Assemblies

1. Follow the **Pressure Relief Procedure** on page 22.
2. Remove wiper assembly; see FIG. 35 on page 50:
  - a. *For all single wiper platens:* Remove two clips (470) with needle nose pliers and remove platen cover (469).
  - b. Remove eight nuts (459) that hold wiper assembly to platen casting (451) and remove wiper assembly.
  - c. See **Reassemble 20, 30, and 60 Liter Wiper Assemblies** to change wiper sizes, styles, or a complete wiper assembly.
3. Remove eight nuts (459) on wiper assembly.
4. Separate top plate (457), spacer (452), wiper(s) (453), wiper support (454), and bottom plate (455).
5. Clean, inspect, and replace worn components.

#### Reassemble 20, 30, and 60 Liter Wiper Assemblies

1. Assemble wiper assembly; see FIG. 35 on page 50:
  - a. *For single wiper assemblies with carbon steel platens:* Place bottom plate (455) on flat surface. Place wiper support (454), wiper (453), spacer (452), and top plate (457) on bottom plate (455).
  - b. *For single wiper assemblies with SST platens:* Place bottom plate (455) on flat surface. Place wiper support (454), wiper (453), flowered wiper support (460), PTFE spacer (452), and top plate (457) on bottom plate (455).
  - c. *For double wiper assemblies:* Place bottom plate (455) on flat surface. Place wiper support (454), wiper (453), spacer (452), wiper (453) and top plate (457) on bottom plate (455).
2. Install eight nuts (459) on outer ring. Torque to 45 in-lbs (61 N•m).
3. Replace o-ring (456), or install new o-ring under platen casting (451). Use lubricant to hold in place.

4. Install platen casting (451). Tighten with four nuts (459).

### Remove 55 Gallon Platen Wipers

1. Follow the **Pressure Relief Procedure** on page 22.
2. Turn the disconnect switch (M) to OFF.
3. To replace worn or damaged wipers (EB), raise platen up out of drum. Remove drum from base. Wipe fluid off of platen.
4. Cut top and bottom wipers with knife and remove from platen. See FIG. 19.

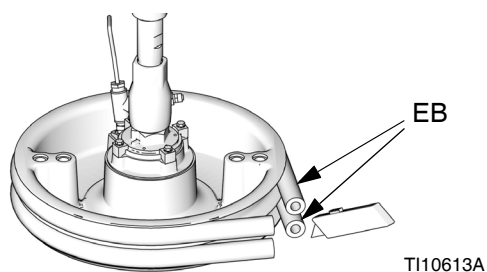

FIG. 19

### Reinstall 55 Gallon Platen Wipers

1. Using a wooden or plastic tool to prevent damage to the wiper (EB), clean all material from seal grooves.
2. *Working from the bottom*, angle one wiper (EB) over back of platen. See FIG. 20.
3. Insert wiper (EB) in top groove and run front of wiper into groove.
4. Insert second wiper (EB) in lower groove and run front of wiper into groove.
5. Lubricate outside of wiper with lubricant compatible with material being pumped. Check with material supplier.

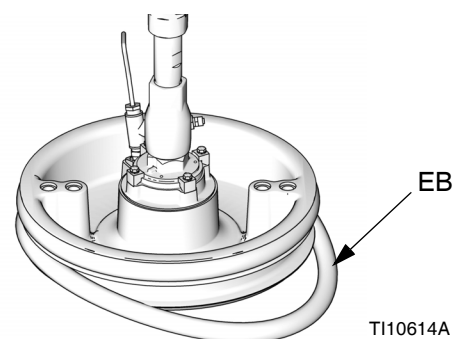

FIG. 20

### Remove 55 Gallon Platen Hose Wipers

1. Follow the **Pressure Relief Procedure** on page 22.
2. Turn the disconnect switch (M) to OFF.
3. To replace worn or damaged wipers (EB), raise platen up out of drum. Remove drum from base. Wipe fluid off of platen.
4. Loosen ends of banding (410) with jack screw. See FIG. 21.

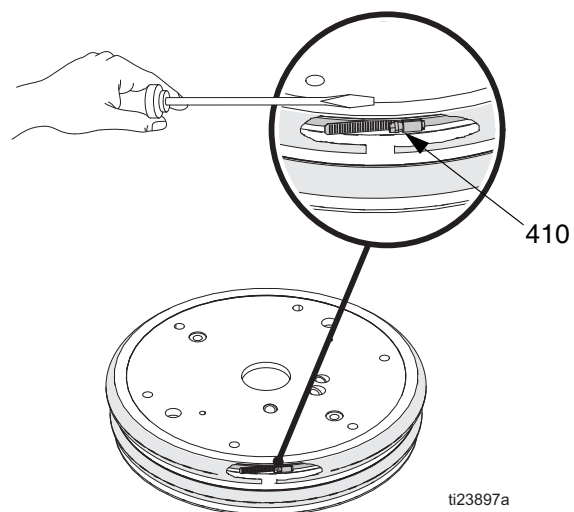
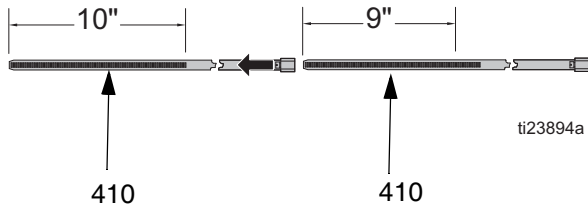

FIG. 21

**Reinstall 55 Gallon Plate Hose Wipers**

1. Clean all material from the seal grooves. Lubricate ram plate grooves before assembly.
2. Assemble two bands (410) together. Align one end of band about 9 in. from jack screw and tape attached band. Install screw jack in slot.



3. Insert jack screw end of band (410) into hose (408 or 409) and push completely through hose.

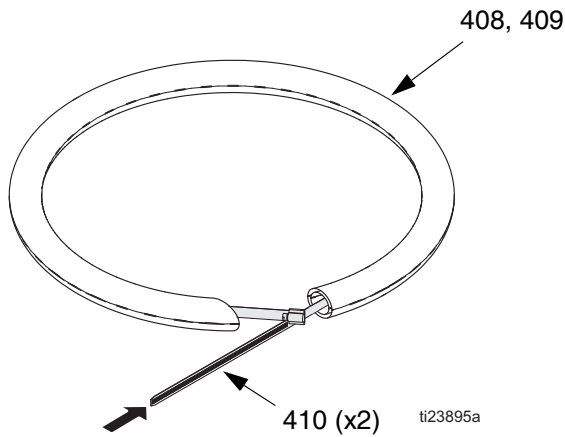

**NOTE:** To prevent material from potentially leaking past both hoses, ensure hose (408,409) seams are 90°-180° apart, and not on top of each other.

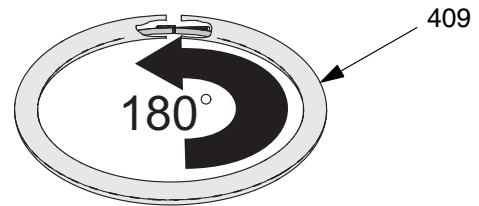
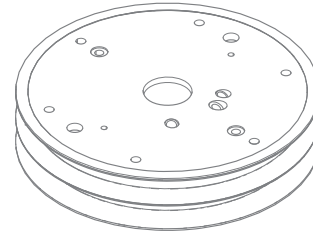
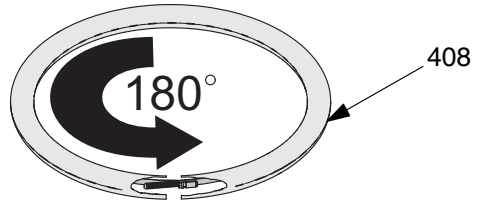

4. Lubricate outside of hoses (408,409) and place on upper or lower groove on plate. Adjust hose and band so that the angled ends of hose press against each other. Tighten two ends of banding (410) together with jack screw.

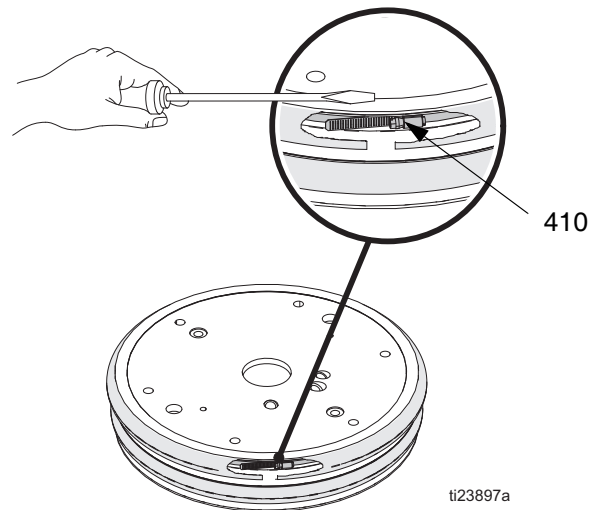

5. Work hose to completely close gap at the ends.

# Troubleshooting

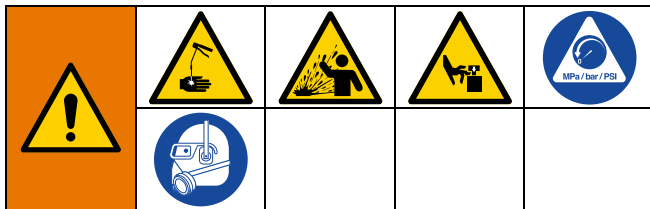

1. Follow **Pressure Relief Procedure**, page 22, before checking or repairing the ram, pump, or platen.

2. Check all possible problems and causes before disassembling the ram, pump, or platen.

**NOTE:** Refer to Supply Unit Operation manual for descriptions of DataTrak diagnostic codes.

**NOTE:** Refer to your pump package manual for pump troubleshooting.

Problem	Cause	Solution
Ram will not raise or lower.	Closed air valve or clogged air line.	Open, clear.
	Not enough air pressure.	Increase.
	Worn or damaged piston.	Replace. See <b>Supply Unit Repair</b> on page 34.
	Hand valve closed or clogged.	Open, clear.
Ram raises and lowers too fast.	Air pressure is too high.	Decrease.
Air leaks around cylinder rod.	Worn rod seal.	Replace. See <b>Supply Unit Repair</b> on page 34.
Fluid squeezes past ram plate wipers.	Air pressure too high.	Decrease.
	Worn or damaged wipers.	Replace. See <b>Remove and Reinstall Wipers</b> on page 26.
Pump will not prime properly or pumps air.	Not enough pressure.	Increase pressure setting.
	Worn or damaged piston.	Replace. See pump manual.
	Hand valve closed or clogged.	Open, clear. See <b>Platen Maintenance</b> on page 25.
	Hand valve is dirty, worn, or damaged.	Clean, service.
Air assist valve will not hold drum down or push plate up.	Closed air valve or clogged air line.	Open, clear. See <b>Platen Maintenance</b> on page 25.
	Not enough air pressure.	Increase.
	Valve passage clogged.	Clean. See <b>Platen Maintenance</b> on page 25.

# Repair



## Disconnect Pump from Platen

The pump is mounted to the platens by different mounting kits. See the Repair Kits on page 55.

### 55 Gallon Platen

1. Follow the **Pressure Relief Procedure** on page 22.
2. Turn the disconnect switch (M) to OFF.
3. Remove four hex screws (426), four clamps (427), and washers (425).

4. Carefully pull pump away to prevent damage to pump inlet and remove o-ring (428).

### 20, 30, and 60 Liter Platen

1. Follow the **Pressure Relief Procedure** on page 22.
2. Turn the disconnect switch (M) to OFF.
3. Loosen two 5/16 in. screws (462) from platen.
4. Carefully pull pump away to prevent damage to pump inlet. If using a pump with intake adapter, remove screws (472), adapter (471), and o-rings (463) from pump inlet.

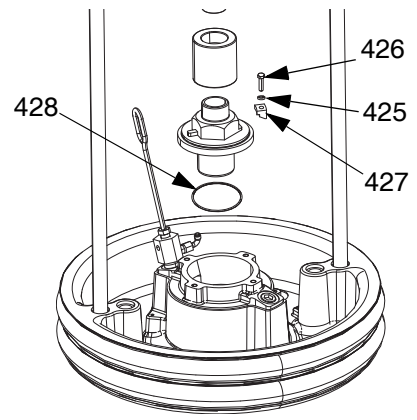
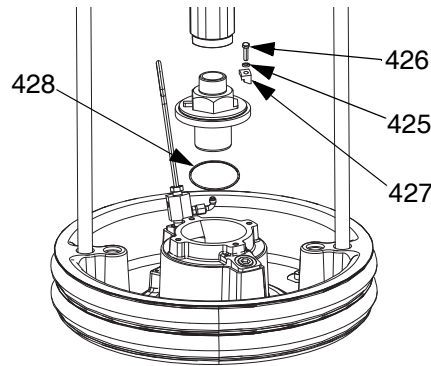
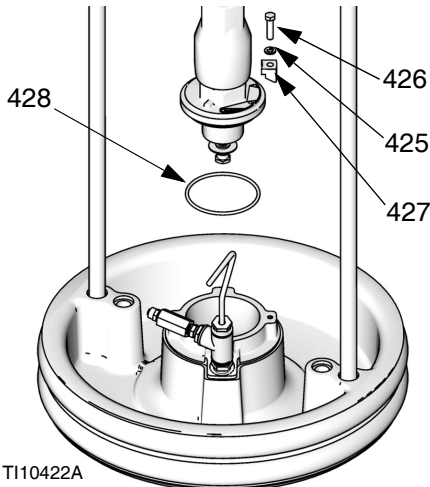

T110422A

**Check-Mate Mounting**

**Dura-Flo SS Mounting**

**Dura-Flo CS Mounting**

**FIG. 22: 55 Gallon Mounting Kit**

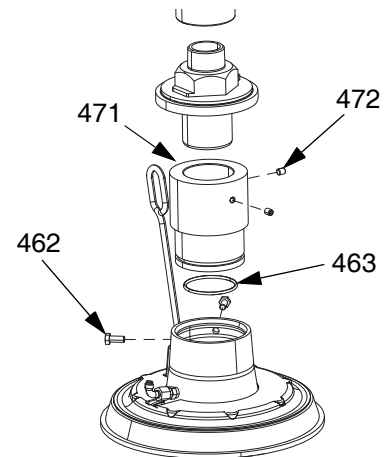
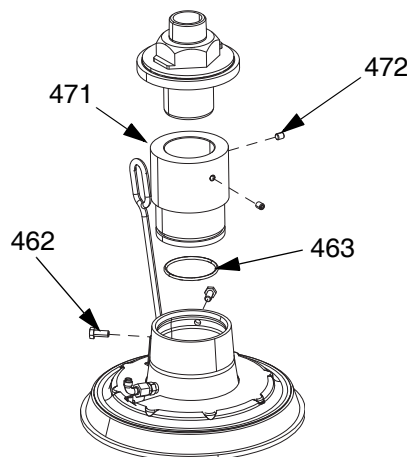
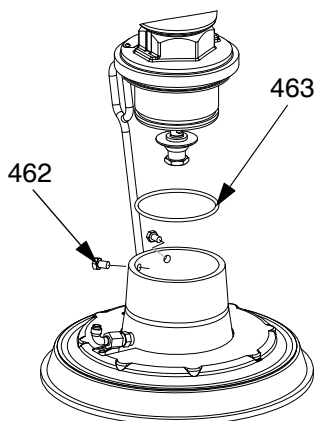

r\_255648\_313527\_35a

**Check-Mate Mounting**

**Dura-Flo SS Mounting**

**Dura-Flo CS Mounting**

**FIG. 23: 20, 30, and 60 liter mounting kit**

## Connect Platen

### 55 Gallon Platen

1. Place o-ring (428) from mounting kit on the platen. If attached to plate, place displacement pump onto platen. See FIG. 22.
2. Secure pump's intake flange to plate with screws (426), washers (425), and clamps (427) included in mounting kit 255392.

### 20, 30, and 60 Liter Platen

**NOTE:** Before installing the 20, 30, or 60 liter platen to a pump with an intake adapter, install adapter and o-ring from mounting kit using the two set screws. See FIG. 23.

1. Place o-ring (463) from mounting kit on pump intake. Loosen the pump intake flange screws (462) and carefully lower pump onto o-ring (463) and platen.
2. Secure pump's intake flange to plate with screws (462).

## Remove Wipers

See **Remove and Reinstall Wipers** on page 26.

## Install Wipers

See **Remove and Reinstall Wipers** on page 26.

## Remove Displacement Pump



The procedure for removing your displacement pump depends on which driver and platen your unit uses. Find your ram unit, driver, and platen below to remove the displacement pump. Refer to your displacement pump manual to repair the displacement pump.

If the driver does not require servicing, leave it attached to its mounting. If the driver does need to be removed, see **Remove Driver** on page 33.

### D200 3 in. and D200s 6.5 in. Supply Units

1. Follow the **Pressure Relief Procedure** on page 22.
2. Turn the disconnect switch (M) to OFF.
3. See **Disconnect Displacement Pump** in your pump package manual.
4. Open the main air slider valve (AA).
5. Raise the driver:
  - a. Loosen nut (105a) under ram bar and thread it down the threaded rod (106) to the lift ring adapter (107) holding the driver. Use wrench on nut (105) on top of ram bar to raise driver.

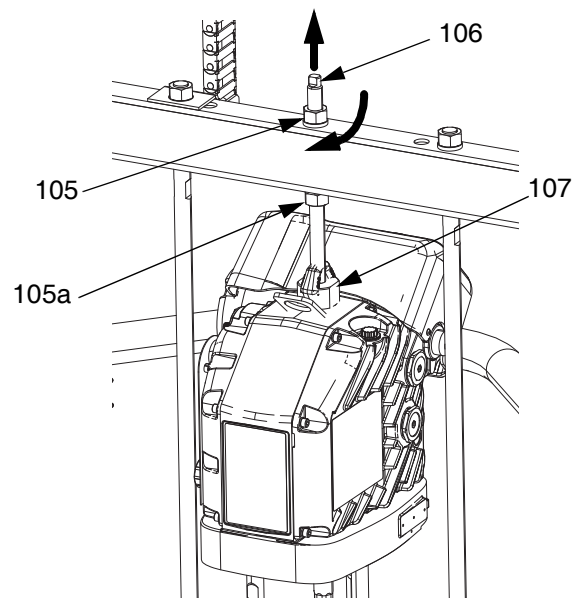

FIG. 24

- b. For driver with smaller platens and all supply units: See procedure for **D60 3 in. Dual Post Supply Units** on page 32.
6. See **Disconnect Pump from Platen** on page 30 to disconnect the platen from the displacement pump.
7. Use two people to lift out the displacement pump.

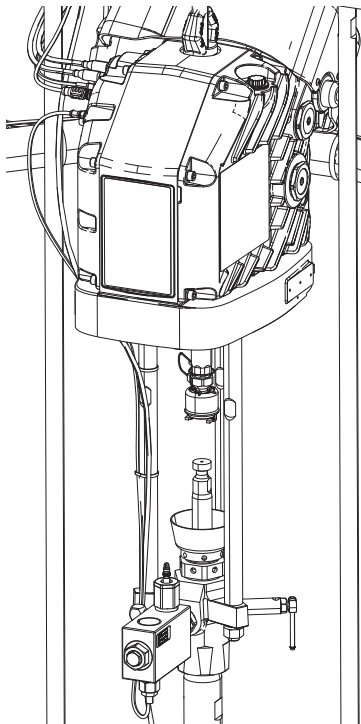

FIG. 25

### D60 3 in. Dual Post Supply Units

1. Follow the **Pressure Relief Procedure** on page 22.
2. Turn the disconnect switch (M) to OFF.
3. See **Disconnect Displacement Pump** in your pump packages manual.
4. See **Disconnect Pump from Platen** on page 30 to disconnect the platen from the displacement pump.
5. Open the main air slider valve (AA).
6. Raise the ram assembly to lift the driver away from the displacement pump.
7. Remove displacement pump and service as needed.

## Install Displacement Pump

### D200 3 in. and D200s 6.5 in. Supply Units

1. Insert displacement pump on platen. Follow **Connect Platen** steps on page 31.
2. See **Reconnect Displacement Pump** in your pump package manual.
3. Connect driver:
  - a. Use wrench on nut (105) on top of ram bar to lower driver onto displacement pump. See FIG. 24 on page 31. Thread nut (105) up and tighten it under ram bar. Tighten nut (105) below the crossbar to 25 ft-lb (34 N•m) maximum.

### D60 3 in. Dual Post Supply Units

1. Raise ram to install displacement pump to platen.
2. Insert displacement pump on platen. Follow **Connect Platen** steps on page 31.
3. See **Reconnect Displacement Pump** in your pump packages manual.



## Remove Driver



To avoid serious injury when installing and removing the driver, make sure the driver is supported at all times.

1. Follow the **Pressure Relief Procedure** on page 22.
2. Turn the disconnect switch (M) OFF.
3. See **Disconnect Displacement Pump** in your pump package manual.
4. Disconnect power from the driver:
  - a. Remove the driver housing cover (HC).
  - b. Disconnect the wires inside the driver housing.
  - c. Loosen the cord grip (CG).
  - d. Remove wires from driver housing by pulling them through the cord grip (CG).
  - e. Disconnect the cables connected to ports 1-6 on the side of the driver, shown in FIG. 27.

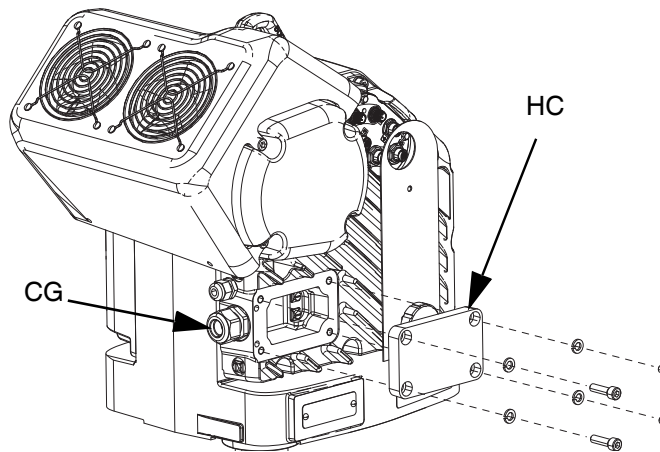

FIG. 26

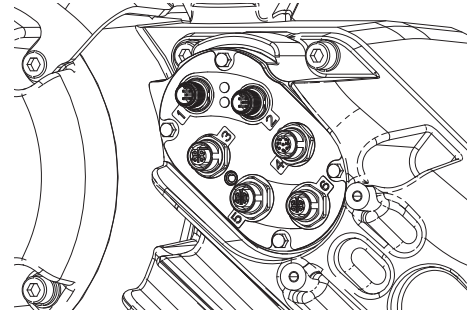

FIG. 27

5. Disconnect driver:
  - a. *D200 3 in. and D200s 6.5 in. supply units:* Loosen nut (125) below crossbar. Use wrench to hold lift ring adapter (127) in place and loosen threaded rod (126) above crossbar with another wrench. See FIG. 28.

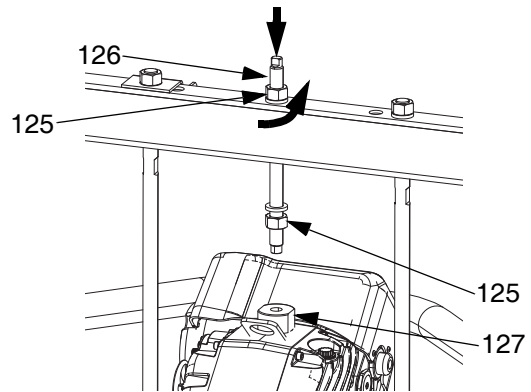

FIG. 28: 55 Gallon Platen

- b. *D60 3 in. supply units:* Remove screws (255) and washers (256) from mounting plate (259). Using a secure hoist, lift the driver from the mounting plate (259). See FIG. 29.

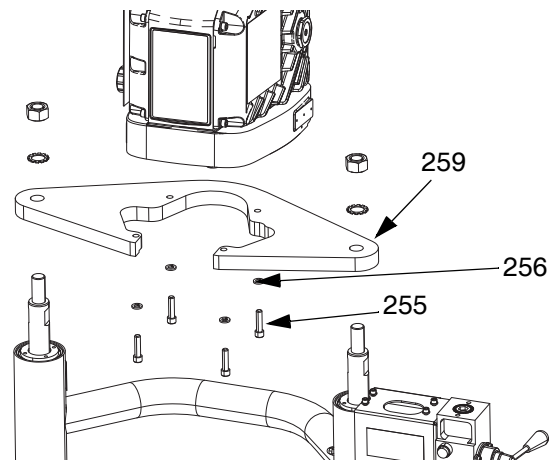
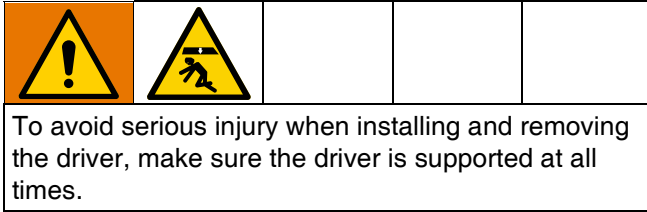

FIG. 29: D60 with Ram

## Install Driver



### D200 3 in. and D200s 6.5 in. Supply Units

#### 55 gallon platen:

1. Using a capable hoist, insert tie rods into displacement pump and secure driver to pump.
  - a. See **Reconnect Displacement Pump** in your pump package manual.
  - b. Install threaded rod (126) through center hole in the crossbar. Install lock washers (124) and nuts (125) onto threaded rod (126), both above and below crossbar. Use wrench to hold lift ring adapter (127) and tighten threaded rod (106) into lift ring adapter (127) using another wrench. See FIG. 30.
  - c. Tighten nut (125) below crossbar to 25 ft-lb (34 N•m) maximum.
  - d. Tighten nut (125) above crossbar to lock driver in place.

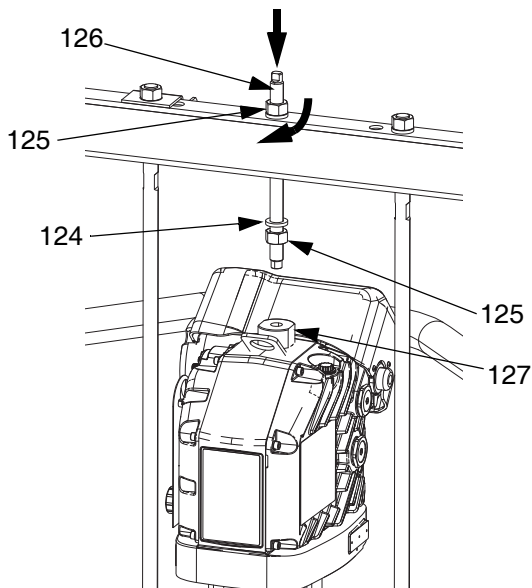

FIG. 30

2. Connect power to the driver. Follow a-e of step 4 on page 33 in reverse.
3. Turn the disconnect switch (M) ON.

### D60 3 in. Dual Post Supply Unit

1. Using a secure hoist, attach driver to mounting plate (259) with screws (255) and washers (256). See FIG. 29 on page 33.
2. See **Reconnect Displacement Pump** in your pump package manual.
3. Connect power to the driver. Follow a-e of step 4 on page 33 in reverse.

## Supply Unit Repair



### D200s 6.5 in. Ram Piston Rods

Always service both cylinders at the same time. When you service the lift rod always install new o-rings in the piston rod seal and ram piston.

#### Disassemble Piston Rod Seal

1. Follow the **Pressure Relief Procedure** on page 22.
2. Turn the disconnect switch (M) OFF.
3. Remove the nuts (123) and lockwashers (122) holding the tie bar (219) to the piston rods (132). See parts illustration on page 38.
4. Remove nuts (303, 305) and washers (302, 304). See parts illustration on page 44.
5. Lift tie bar (219) off of rods.
6. Remove retaining ring (136) by gripping the ring tab with a pair of pliers and rotating the ring out of its groove.
7. Remove snap ring (134) and rod wiper (133).
8. Remove guide sleeve (135) by sliding it off of rod (132). Four 1/4 in -20 holes are provided to ease removal of the guide sleeve.

- Inspect parts for wear or damage.

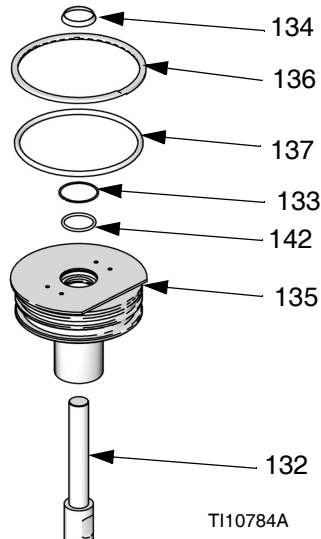

**FIG. 31: 6.5 in. Piston Rod Seal**

**Assemble Piston Rod Seal**

- Install new o-rings (137,142), rod wiper (133), and snap ring (134). Lubricate packings with o-ring lubricant.
- Slide guide sleeve (135) onto rod (132) and push it into cylinder. Replace retaining ring (136) by feeding it around the guide sleeve groove.
- Reinstall tie bar (219) using nuts (123) and lock-washers (122). Torque to 40 ft-lb (54 N•m).
- Reinstall washers (302, 304) and nuts (303, 305).

**Disassemble Ram Piston**

- Follow the **Pressure Relief Procedure** on page 22.
- Turn the disconnect switch (M) OFF.
- Remove nuts (123) and lockwashers (122) holding the tie bar (219) to the piston rods (132). See page 38.
- Remove nuts (303, 305) and washers (302, 304). See parts illustration on page 44.
- Lift tie bar (219) off rods.
- Remove retaining ring (136) by gripping the ring tab with a pair of pliers and rotating the ring out of its groove.

- Remove guide sleeve (135) and slide it off piston rod (132).

**NOTICE**

**Do not** tilt the piston rod to one side when removing it from the base or when installing it. Such movement can damage the piston or inside surface of the base cylinder.

- Carefully lay piston (141) and rod (132) down so rod will not be bent. Remove bottom retaining ring (138) and o-ring (139). Remove piston guide band (140). Slide piston (141) off piston rod (132).

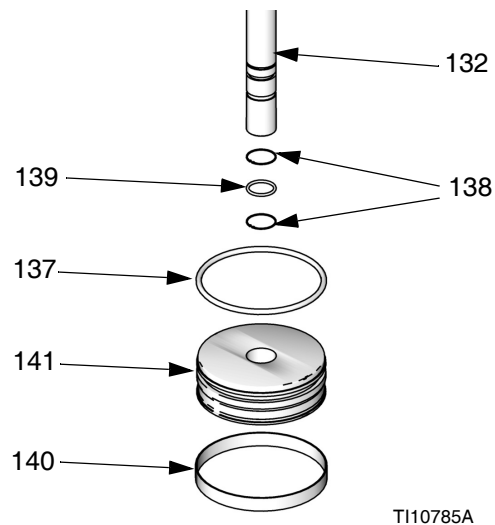

**FIG. 32: 6.5 in. Ram Piston**

**Assemble Ram Piston**

- Install new o-rings (139, 137) on piston rod (132) and piston (141). Lubricate the piston (141) and o-rings (139, 137). Reinstall piston (141) and lower retaining ring (138) onto piston rod (132). Install piston guide band (140) onto piston (141).
- Carefully insert piston (141) into cylinder and push rod (132) straight down into cylinder. Add three ounces of lubricant to each cylinder after inserting the piston (141).
- Slide guide sleeve (135) onto piston rod (132).
- Install retaining ring (134) and tie bar (219). Perform steps to **Disassemble Ram Piston** in reverse order.

## D200 and D60 3 in. Ram Piston Rods

Always service both cylinders at the same time. When you service the piston rod always install new o-rings in the piston rod seal and ram piston.

### Disassemble Piston Rod Seal and Bearing

1. Follow the **Pressure Relief Procedure** on page 22.
2. Access piston rod seal and bearing.
  - a. *For D200 3 in. Ram:* Remove nuts (125) and lockwashers (124) holding the tie bar (219) to the piston rods (246). Remove nuts (305) and washers (304). Remove tie bar (219). Refer to parts illustration on page 40.
  - b. *For D60 3 in. Ram:* Ensure ram is in lowest position. Remove nuts (125) and lockwashers (254) from piston rods (261). Remove entire pump package, including the mounting plate (259) off of the piston rods (261). Secure pump package so pump and platen will not fall. See page 45.
3. Remove retaining ring (218).
4. Remove piston rod seal and bearing.
  - a. Slide end cap (241), pin (238), o-ring (245), and spring (244) up off of the piston rod (261, 246). Remove retaining ring (242) and bearing (243) from end cap (241) and remove o-ring (240).
5. Inspect parts for wear or damage. Replace as necessary.

**NOTE:** Do not reinstall end cap assembly if the ram piston (247) needs to be removed from the piston rod. See the next page for ram piston repair instructions.

D200 and D60 3 in. Rams

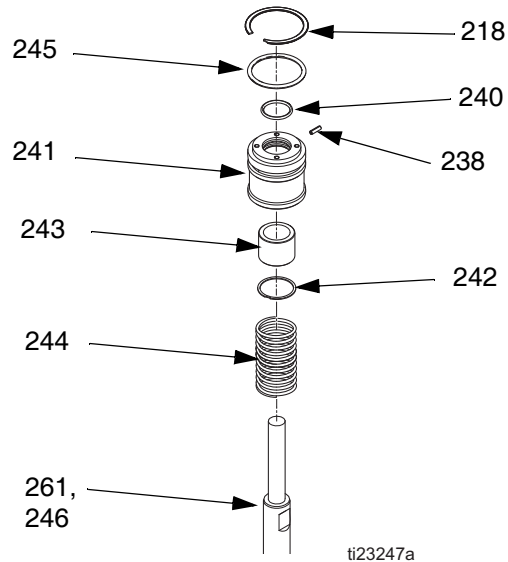

**FIG. 33: 3 in. Piston Rod Seal**

### Assemble Piston Rod Seal and Bearing

See FIG. 33 on page 36.

1. Lubricate o-ring (240) and bottom bearing (243).
  - a. Install o-ring (240), bottom bearing (243), and retaining ring (242) into end cap (241).
  - b. Install new o-ring (245) and pin (238) on end cap (241). Lubricate o-ring (245) and end cap (241).
  - c. Slide spring (244) and end cap (241) on piston rod (261, 246).
2. Install retaining ring (218).
3. *For D200 3 in Ram:* Install tie bar (219), washers (124), and nuts (125).
4. *For D60 3 in. Ram:* Remount mounting plate (259) and attach nuts (255) and lockwashers (256). Torque to 40 ft-lb (54 N•m).

### Disassemble Ram Piston

1. Complete steps 1-4 from **Disassemble Piston Rod Seal and Bearing** to remove the end cap from the piston rod.

#### NOTICE

**Do not** tilt the piston rod to one side when removing it from the base or when installing it. Such movement can damage the piston or inside surface of the base cylinder.

2. Carefully lay piston (247) and rod (261, 246) down so piston rod will not be bent. Remove nut (125), washer (124), piston (247), outer o-ring (245), and inner o-ring (239).
3. Inspect parts for wear or damage. Replace as necessary.

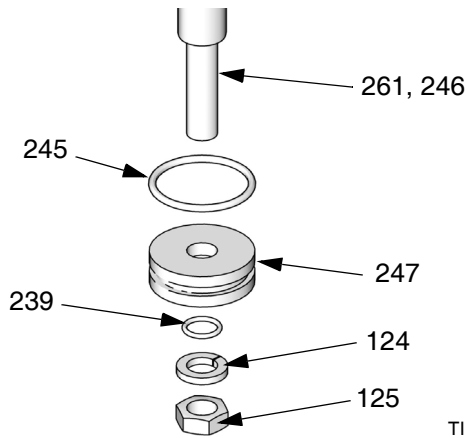

TI10521A

**FIG. 34: 3 in. Ram Piston**

### Assemble Ram Piston

1. Install new o-rings (245, 239) and lubricate piston (247) and o-rings.
2. Apply medium strength thread sealant. Install piston (247), washer (124), and nut (125) on piston rod (261, 246).
3. Carefully insert piston (247) into cylinder and push piston rod (261, 246) straight down into cylinder.
4. Slide spring (244) and end cap (241) onto piston rod (261, 246).
5. *For D200 3 in. Rams:* Install retaining ring (218), tie bar (219), washers (124), and nuts (125).
6. *For D60 3 in. Rams:* Install retaining ring (218) and install mounting plate (259) with nuts (255) and washers (256) with pump package and platen.

# Parts

## D200s 6.5 in. Supply Units

Model 25E201 Shown

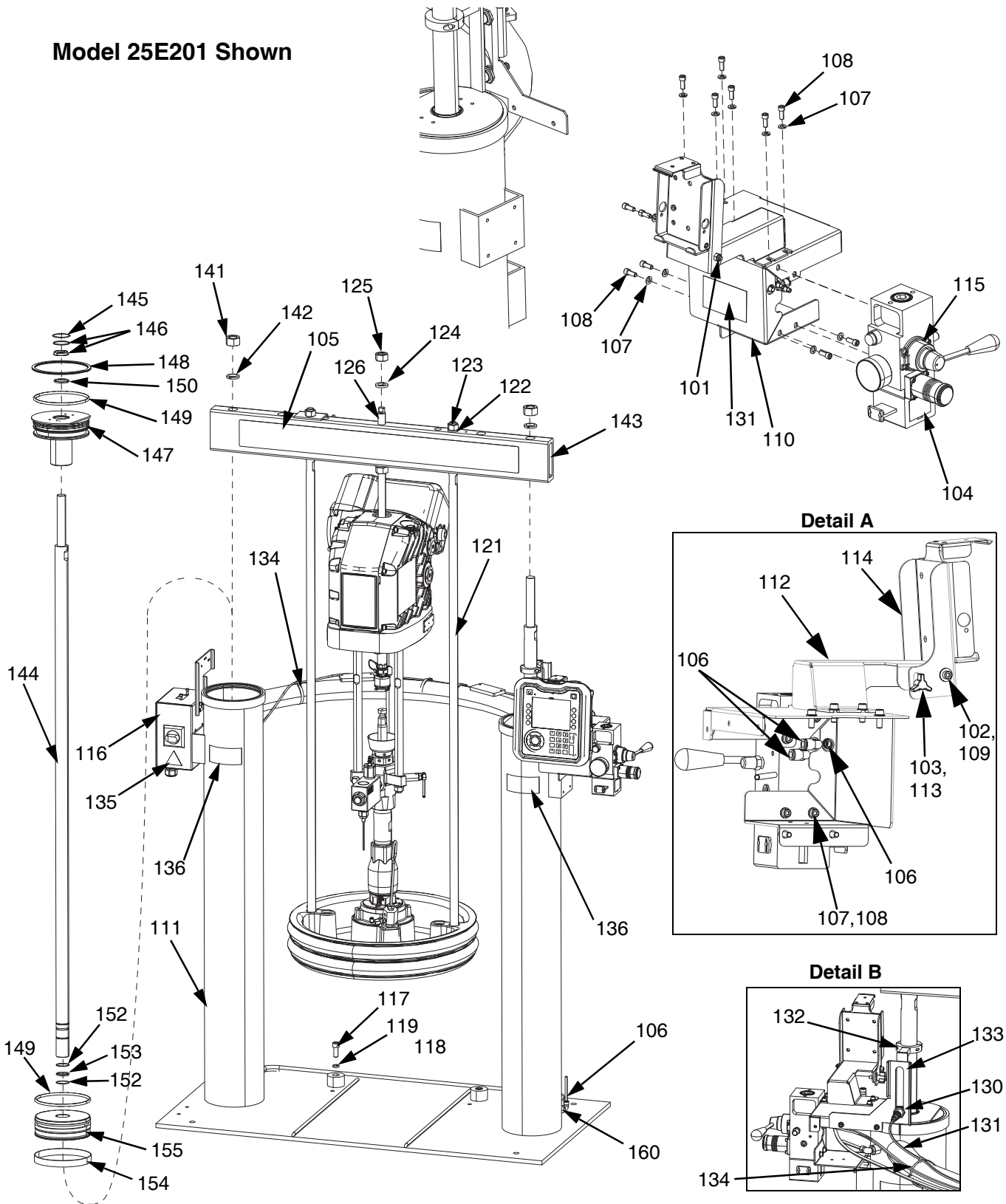

## D200s 6.5 in. Supply Units, 25E201

Ref.	Part	Description	Qty.	Ref.	Part	Description	Qty.
101	102040	NUT, lock, hex	1	132	24D006	ACTUATOR, sensor, low/empty, wmmilt, pt	1
102	110755	WASHER, plain	1	133	17Y704	BRACKET, lvl sensor, dual, d200s. pnt	1
103	117017	WASHER	1	134	114958	STRAP, tie	7
104	15V954	LABEL, valve, shutoff, air control	1	135▲	196548	LABEL, caution (Junction Box)	1
105	16W583	LABEL, cross bar	1	136▲	15J074	LABEL, safety, crush & pinch	4
106	C12509	TUBE, nylon, rnd	15	141	113939	NUT, jam, hex	2
107	100016	WASHER, lock	15	142	113933	WASHER, lock, helical	2
108	121112	SCREW, cap, socket head	15	143	15M538	BEAM, tie, 6.5 in. ram	1
109	121250	SCREW, shch	1	144	C32401	ROD	2
110	255375	BRACKET, mounting, painted	1	145*	C03043	RING, snap	2
111	255438	RAM, 6.5 in.	1	146*	C31001	WIPER, rod	2
112	255633	BRACKET, pendant pivot, painted	1	147	25T845	SLEEVE, guide	2
113	121253	KNOB, display adj., ram pkgs	1	148*	C32409	RING, retaining	2
114	255639	BRACKET, mounting, assembly	1	149*	C38132	PACKING, o-ring	4
115	24C264	CONTROL, air, ram, hyd driver	1	150*	C02073	PACKING, quad ring	2
116	25E207	JUNCTION BOX, ram mounted, e-drive	1	152*	C20417	RING, retaining	4
117	C19853	SCREW, cap, socket hd	2	153*	158776	PACKING, o-ring	2
118	C32467	STOP, drum	2	154*	C32408	BAND, guide	2
119	C38185	WASHER, lock	2	155	C32405	PISTON, elevator air	2
120X	070408	SEALANT, pipe, sst	1	157X	100040	PLUG, pipe	2
121	15M531	ROD, follower	2	160	114153	FITTING, elbow, male, swivel	2
122	101015	WASHER, lock	2				
123	C19187	NUT, nex	2				
124	101533	WASHER, spring lock	2				
125	101535	NUT, full hex	2				
126	15J992	ROD, threaded	1				
127X	15J991	ADAPTER, lift ring	1				
128X	15J993	RING, lift, plate	1				
129X	073028	LUBRICANT, anti-seize	1				
130	130787	SENSOR, barrel, m18 x 1, pnp, nc PKG	1				
131	123656	CABLE, spin, male/female	1				

▲ Replacement safety labels, tags, and cards are available at no cost.

\* Parts included in Supply Units Repair Kit 918432 (purchase separately).

X Not shown.

# D200 3 in. Supply Units

Model 25E200 Shown

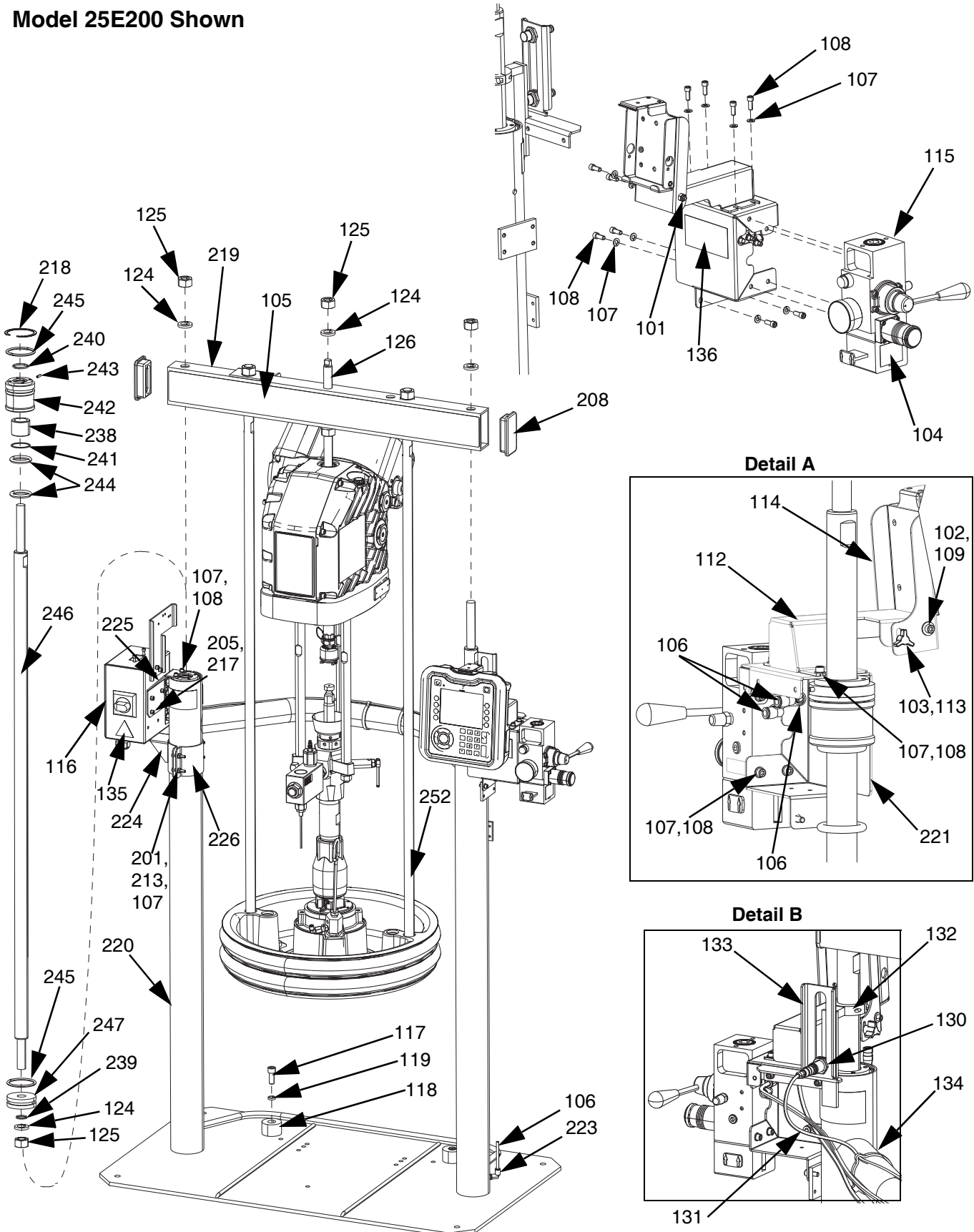



**D200 3 in. Supply Units, 25E200**

Ref.	Part	Description	Qty.	Ref.	Part	Description	Qty.
101	102040	NUT, lock, hex	1	201	100014	SCREW, cap, hex hd	4
102	110755	WASHER, plain	1	205	108050	WASHER, lock, spring	6
103	117017	WASHER	1	208	189559	CAP, end	2
104	15V954	LABEL, valve, shutoff, air control	1	213	100015	NUT, hex mscr	4
105	16W583	LABEL, cross bar	1	217	121518	SCREW, cap, shc	6
106	C12509	TUBE, nylon, rnd	15	218*	127510	RING, retaining, internal	2
107	100016	WASHER, lock	16	219	167646	BEAM, tie	1
108	121112	SCREW, cap, socket head	12	220	255286	RAM, weldment, 3"	1
109	121250	SCREW, shcs	1	221	255296	BRACKET, mounted, painted	1
112	255633	BRACKET, pendant pivot, painted	1	223	128863	FITTING, elbow	2
113	121253	KNOB, display adj., ram pkgs	1	224	15W703	BRACKET, mounting, btm	1
114	255639	BRACKET, mounting, assembly	1	225	16A314	BRACKET, mounting, acc. box	1
115	24C264	CONTROL, air, ram, hyd driver	1	226	16A566	BRACKET, mounting, ram	1
116	25E207	JUNCTION BOX, ram mounted, e-drive	1	234X	070303	LUBRICANT, grease	1
117	C19853	SCREW, cap, socket hd	2	235X	073021	LUBRICANT, oil	1
118	C32467	STOP, drum	2	237X	070615	SEALANT, thread, med strength	1
119	C38185	WASHER, lock	2	238*	121259	BEARING, ram end cap	1
120X	070408	SEALANT, pipe, sst	1	239*	156401	PACKING, o-ring	1
124*	101533	WASHER, spring lock	6	240*	156698	PACKING, o-ring	1
125*	101535	NUT, full hex	6	241*	15F453	RETAINER, retaining ring	1
126	15J992	ROD, threaded	1	242	15M295	BEARING, ram end cap	1
127X	15J991	ADAPTER, lift ring	1	243	15U979	PIN, spring, straight	1
128X	15J993	RING, lift, plate	1	244*	160138	SPRING, compression	1
129X	073028	LUBRICANT, anti-seize	1	245*	160258	PACKING, o-ring, buna-n	2
130	130787	SENSOR, barrel, m18 x 1, pnp, nc PKG	1	246	167651	ROD, piston ram	1
131	123656	CABLE, spin, male/female	1	247	183943	PISTON	1
132	255381	ACTUATOR, sensor, low/empty, painted	1	251X	C20987	PACKING, o-ring	1
133	17Y702	BRACKET, lvl sensor, dual, d200, PKG	1	252	167652	ROD, tie ram	2
134	114958	STRAP, tie	7				
135▲	196548	LABEL, caution (Junction Box)	1				
136▲	15J074	LABEL, safety, crush & pinch	4				

▲ Replacement safety labels, tags, and cards are available at no cost.

\* Parts included in Supply Units Repair Kit 255687 (purchase separately).

X Not shown.

# D60 3 in. Supply Units

Model 25E199 Shown

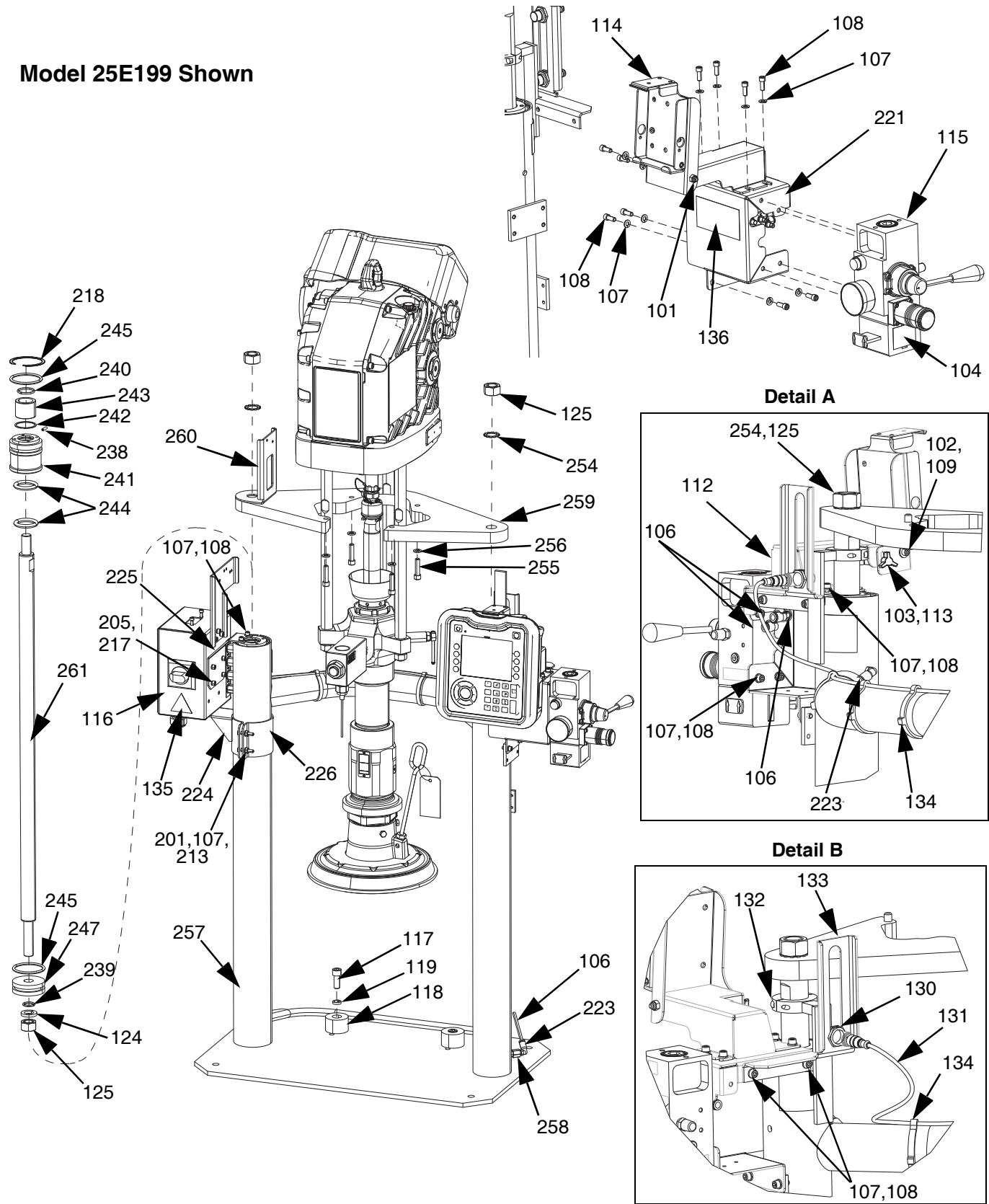

## D60 3 in. Supply Units, 25E199

Ref.	Part	Description	Qty.	Ref.	Part	Description	Qty.
101	102040	NUT, lock, hex	1	218*	127510	RING, retaining, internal	2
102	110755	WASHER, plain	1	221	255296	BRACKET, mounted, painted	1
103	117017	WASHER	1	223	128863	FITTING, elbow	2
104	15V954	LABEL, valve, shutoff, air control	1	224	15W703	BRACKET, mounting, btm	1
106	C12509	TUBE, nylon, rnd	2	225	16A314	BRACKET, mounting, acc. box	1
107	100016	WASHER, lock	18	226	16A566	BRACKET, mounting, ram	1
108	121112	SCREW, cap, socket head	14	234X	070303	LUBRICANT, grease	1
109	121250	SCREW, shch	1	235X	073021	LUBRICANT, oil	1
112	255633	BRACKET, pendant pivot, painted	1	237X	070615	SEALANT, thread, med strength	1
113	121253	KNOB, display adj., ram pkgs	1	238*	121259	BEARING, ram end cap	1
114	255639	BRACKET, mounting, assembly	1	239*	156401	PACKING, o-ring	1
115	24C264	CONTROL, air, ram, hyd driver	1	240*	156698	PACKING, o-ring	1
116	25E207	JUNCTION BOX, ram mounted, E-drive	1	241*	15F453	RETAINER, retaining ring	1
117	C19853	SCREW, cap, socket hd	2	242	15M295	BEARING, ram end cap	1
118	C32467	STOP, drum	2	243	15U979	PIN, spring, straight	1
119	C38185	WASHER, lock	2	244*	160138	SPRING, compression	1
120X	070408	SEALANT, pipe, sst	1	245*	160258	PACKING, o-ring, buna-n	2
124*	101533	WASHER, spring lock	1	247	183943	PISTON	1
125*	101535	NUT, full hex	3	254	104395	WASHER, lock, tooth, external	2
130	130787	SENSOR, barrel, m18 x 1, pnp, nc PKG	1	255	110141	SCREW, cap, sch	4
1313	123673	HARNESS	1	256	100133	WASHER, lock, 3/8	4
132	255381	ACTUATOR, sensor, low/empty, painted	1	257	256734	RAM, dp, weldment	1
133	17Y702	BRACKET, lvl sensor, dual, D200, pkg	1	258	16T421	ADAPTER, pipe hex	1
134	114958	STRAP, tie	4	259	17L703	BRACKET, shelf, D60, 3400/6500	1
135▲	196548	LABEL, caution (Junction Box)	1	260	17X806	BRACKET, cable track, D60 ram PKG	1
136▲	15J074	LABEL, safety, crush & pinch	4	261	15V697	ROD, piston, dp ram	1
201	100014	SCREW, cap, hex hd	4	▲ Replacement safety labels, tags, and cards are available at no cost.			
205	108050	WASHER, lock, spring	6	* Parts included in Supply Units Repair Kit 255687 (purchase separately).			
213	100015	NUT, hex mscr	4	X Not shown.			
217	121518	SCREW, cap, shc	6				

# D200s and D200 Pump Mounts for 55 Gallon (200 Liter) Platen

**Note:** See page 38 for kit configuration table.

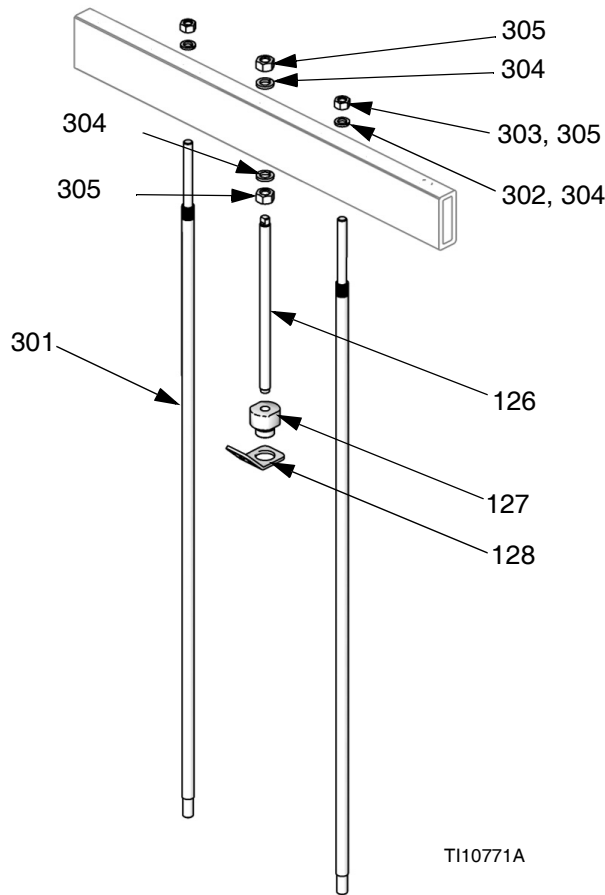

Ref.	Part	Description	Qty	Ref.	Part	Description	Qty
301	15M531 167652	ROD, platen	2	128	15J993	RING, lift, plate	1
302	101015	WASHER, lock	2	324 <del>X</del>	160327	FITTING, 3/4 nptf x 3/4 npsm, 90°	1
303	C19187	NUT, hex	2	325 <del>X</del>	C12034	HOSE, coupled; 72 in.	1
304	101533	WASHER, spring lock	2	326 <del>X</del>	552071	SLEEVE, protective, 6 ft	1
305	101535	NUT, full hex	2	327 <del>X</del>	105281	FITTING, 3.4 nptf x 3/4 npsm, 45°	1
126	15J992	ROD, threaded	1	<del>X</del> Not shown.			
127	15J991	ADAPTER, lift, ring	1				

# D60 Pump Mount 257624 for 5 Gallon (20 Liter) Platen

**Note:** See page 38 for kit configuration table.

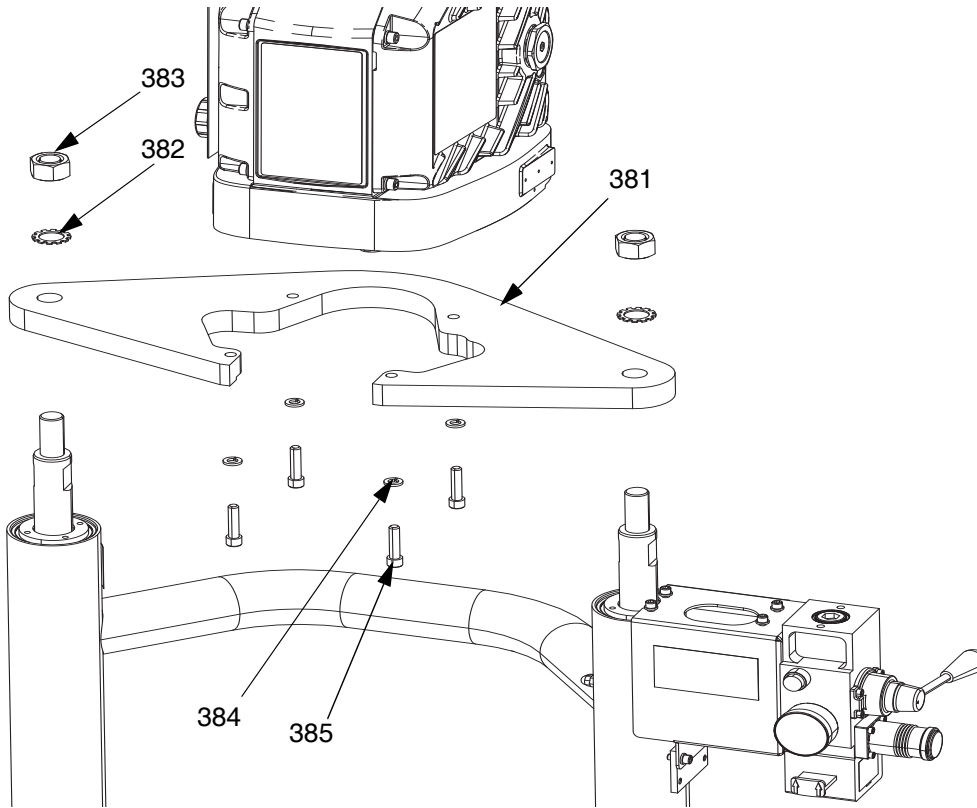

Ref.	Part	Description	Qty.
381	*	BRACKET, shelf, NXT3400 and NXT6500	1
382	101533	WASHER, spring lock	2
383	101535	NUT, hex	2
384	100133	WASHER, lock	4
385	C38372	SCREW, cap, hex head	4
388	X	SLEEVE, protective; 72 in.	1
389	X	STRAP, tie	2
390	X	HOLDER, cable tie, rotating	2
391	X160327	FITTING, 3/4 nptf x 3/4 npsm, 90°	1

\* For 257624 only.

X Not shown.

# Transformer

6.5 in. Ram Transformer Kit 25E202

3 in. Ram Transformer Kit 25E203

1 Tighten u-bolt nuts until lock washers are flattened. Over-tightening may damage ram cylinder.

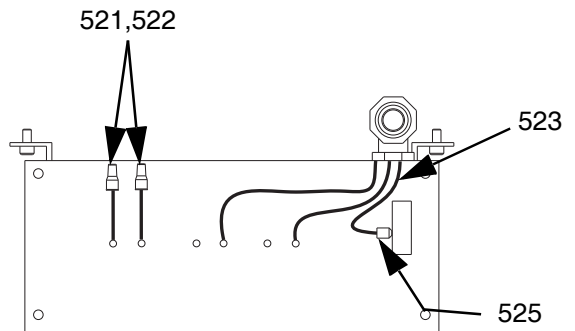
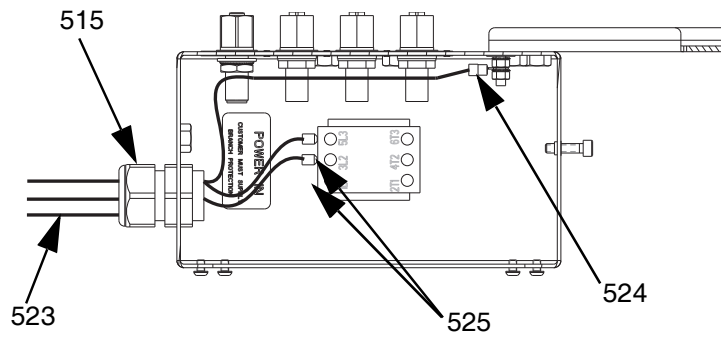
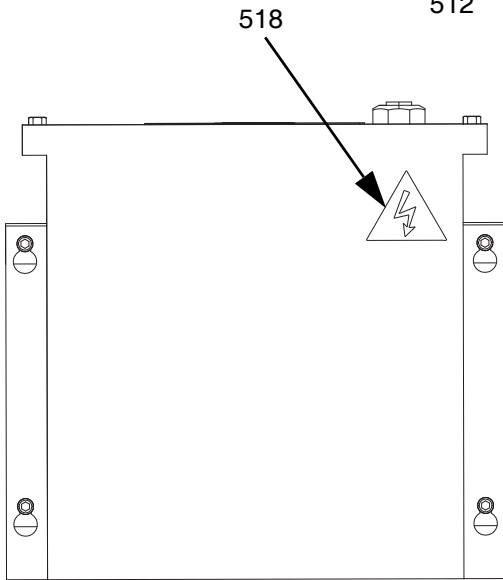
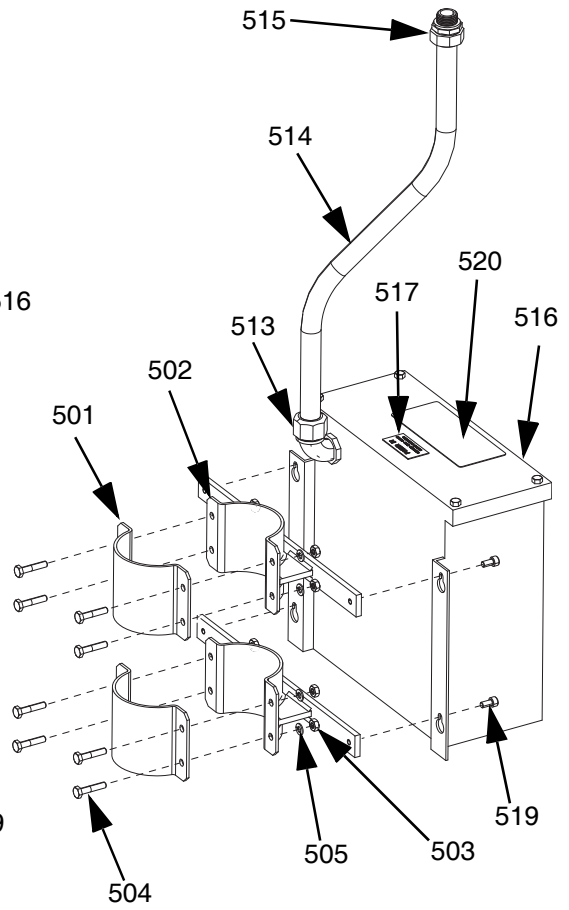
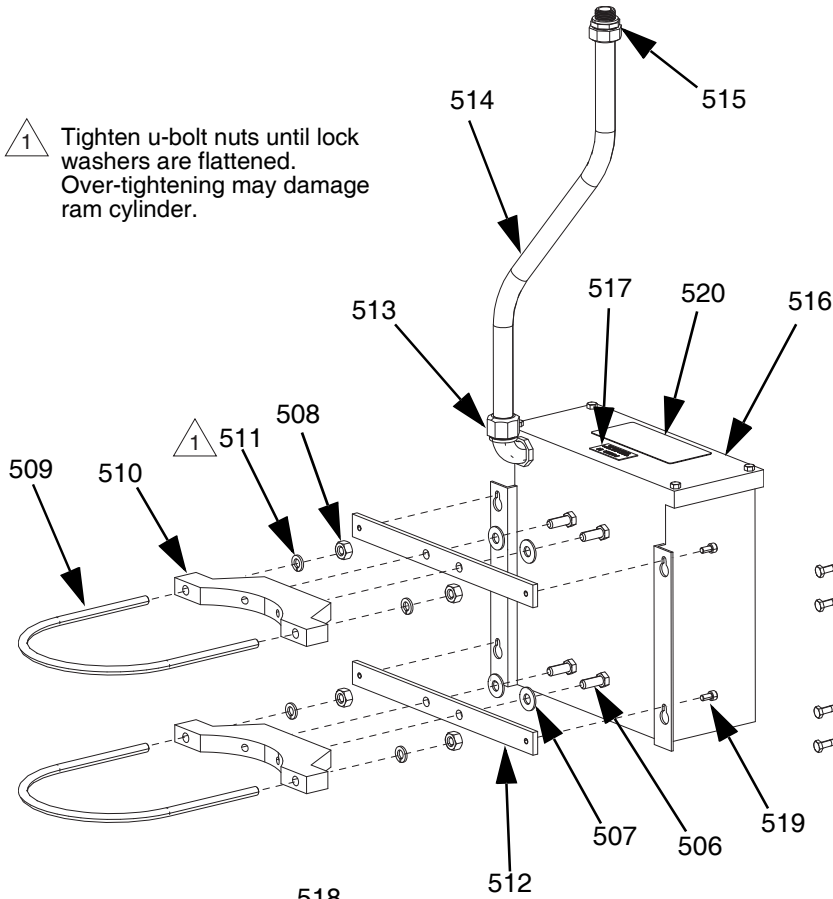

## Transformer Parts

Ref.	No.	Part No.	Description	Qty.
	501*	16A566	BRACKET, mounting, ram, 3 in.	2
	502*	17X839PKG	BRACKET, mounting, xformer, 3 in. ram, painted	2
	503*	100015	NUT, hex mscr	8
	504*	100014	SCREW, cap, hex hd	8
	505*	100016	WASHER, lock	8
	506**	100101	SCREW, cap, hex hd	4
	507**	C19200	WASHER, plain	4
	508**	100131	NUT, full hex	4
	509**	C32424	BOLT, u, 7 in.	2
	510**	617395	CLAMP, saddle	2
	511**	100133	WASHER, lock, 3/8	8
	512**	17X836	BAR, xformer mounting, 6 in. ram, painted	1
	513	17D989	CONNECTOR, conduit, liquid-tight	1
	514	120800	CONDUIT, 1/2	1
	515	17D987	CONNECTOR, conduit, liquid-tight	1
	516	129626	TRANSFORMER, 480V	1
	517	16K918	LABEL, power in, branch circuit	1
	518	196548	LABEL, caution	1
	519	107530	SCREW, cap, sch, hex	4
	520▲	25E178	LABEL, safety, danger	1
	521	124436	CONNECTOR, splice, wire	2
	522	124437	CAP, splice, wire	2
	523	065388	WIRE, copper, electric	1
	524	124443	TERMINAL, ring, insulated, 1/4	1
	525	127667	FERRULE	2

\* Parts only included in kit 25E202.

\*\* Parts only included in kit 25E203.

▲ Replacement safety labels, tags, and cards are available at no cost.

## Cable Track

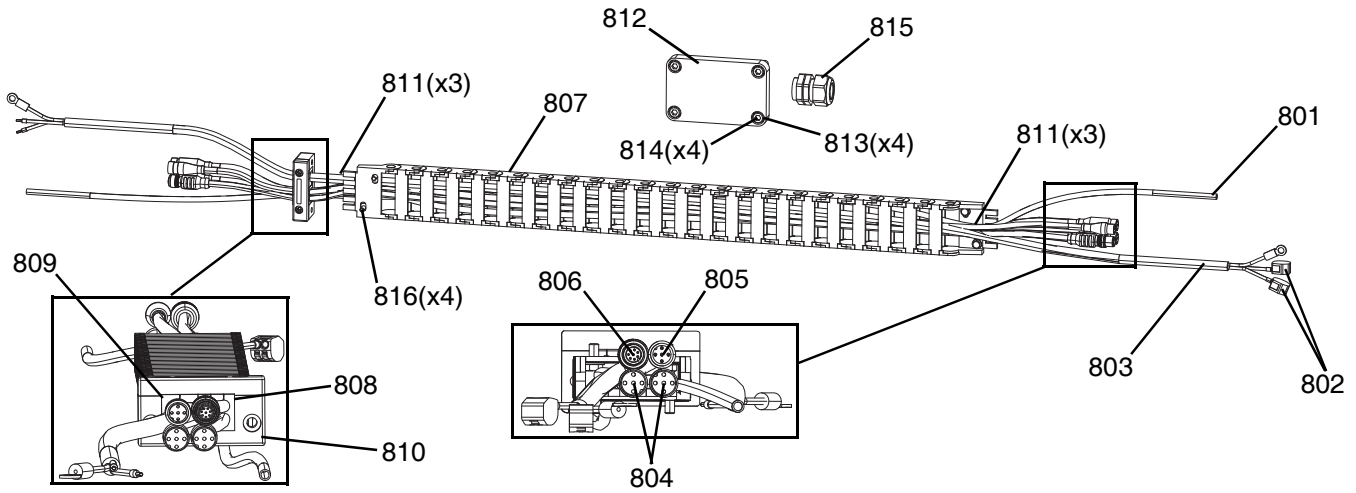

### Cable Tracks, 25E346, 25E347, and 25E348

Ref	Part	Description	Quantity		
			25E346	25E347	25E348
801	C12509	TUBE, nylon, rnd	14 ft	15.5 ft	17.5 ft
802	128986	CONNECTOR, 2 conductor, leverlock	2	2	2
803	131795	CORD, power, d60	1		
	131796	CORD, power, d200		1	
	131797	CORD, power, d200s			1
804	121003	CABLE, can, female / female 3.0 m	2	2	2
805	124415	CABLE, 5pin, mf, 3.0 m, molded	1	1	1
806	125183	CABLE, m12, 8 pin, mf, 2.5 m, molded	1	1	
	15Y051	CABLE, m12, 8 pin, mf, 3.0 m, molded			1
807	17X897PKG	CABLE, track, igus, d60, e-drive	1	1	1
808	128177	INSERT, rubber, cord grip, 4 x 6 mm	1	1	1
809	128397	INSERT, rubber, cord grip, 9-10 mm	1	1	1
810	131664PKG	FRAME, cord grip, 2-position	1	1	1
811	C38321	TIE, cable, 3.62 lg	6	6	6
812	17Y316PKG	COVER, disconnect, painted	1	1	1
813	104572	WASHER, lock spring	4	4	4
814	109114	SCREW, cap, sch	4	4	4
815	121171	GRIP, cord, .35-.63, 3/4	1	1	1
816	128670	BOLT, flange hd, serrated, m5, sst	4	4	4



# 55 Gallon Platen

## 200 Liter (55 Gallon) Platen, 255662, 255663, and 255664

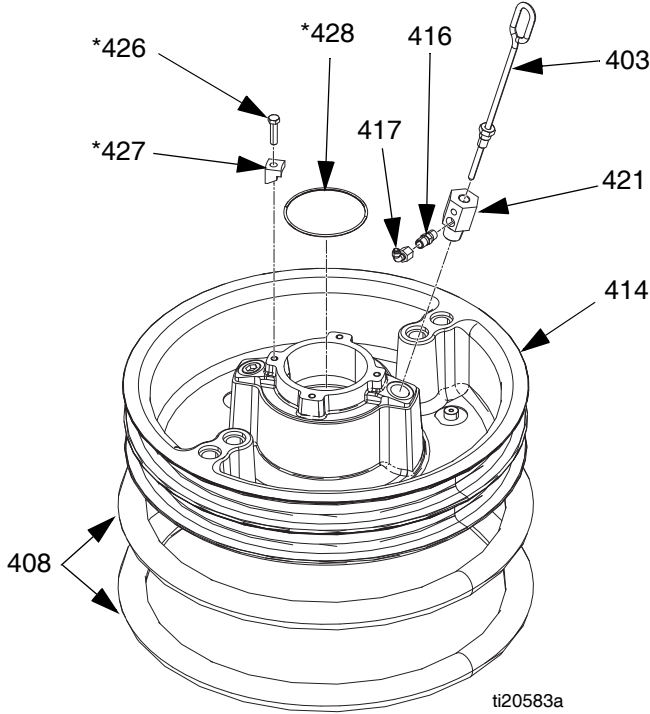

## 200 Liter (55 Gallon) Platen with EPDM Hose Wipers, 24Y343

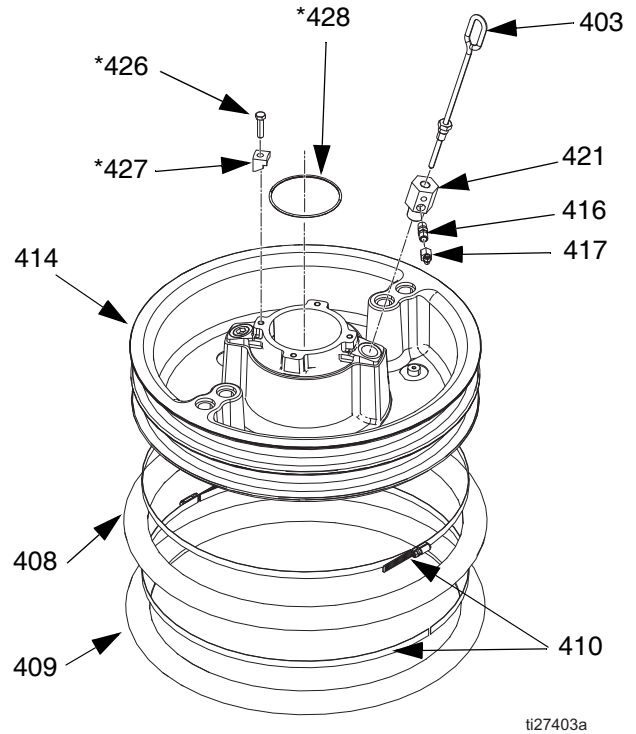

### 200 Liter (55 Gallon) Platen Parts

Ref. No.	Part No.	Description	Qty.
403	257697	HANDLE, bleed assy	1
408◆	255652	SEAL, wiper, drum, 55 gal., neo-prene; for 255664 only.	2
	255653	SEAL, wiper, drum, 55 gal., EPDM; for 255663 and 255662 only.	2
414		PLATE, ram 55 gal., for 255664 and 255663 only.	1
		PLATE, ram 55 gal., PTFE	1
416	122056	VALVE, check, 1/4, for 255662 and 255663 only	1
	501867	VALVE, check, 5/8, for 255664 only	1
417	17E556	FITTING, PTC, elbow, 1/4 NPT, 1/4 TUBE	1
421	15W032	ADAPTER, for 255663, 255664, and 25N344	1
	16W974	ADAPTER, for 255662 only	1
426*⊠◆	102637	SCREW, cap	4
427*⊠◆	276025	CLAMP	4
428*⊠◆	109495	O-RING	1

\* Parts included in 255392 Kit (purchase separately).

⊠ Parts not included with 255662, 663, and 664.

◆ Parts not included with 25N344.

### 200 Liter (55 Gallon) Platen with EPDM Hose Wipers Parts

Ref. No.	Part No.	Description	Qty.
403	257697	HANDLE, bleed assy	1
408†	17L889	SEAL, wiper, drum, 55 gal., EPDM	1
409†	162230	SEAL, wiper, drum, 55 gal., EPDM	1
410†	17B467	CLAMP, tire	4
414		PLATE, ram 55 gal.	1
416	122056	VALVE, check, 1/4	1
417	17E556	FITTING, PTC, elbow, 1/4 NPT, 1/4 TUBE	1
421	15W032	ADAPTER	1
426*⊠	102637	SCREW, cap	4
427*⊠	276025	CLAMP	4
428*⊠	109495	O-RING	1

\* Parts included in 255392 Kit (purchase separately).

† Parts included in 25M210 Kit (purchase separately).

⊠ Parts not included with 24Y343.

# 20 Liter (5 Gallon), 30 Liter (8 Gallon), and 60 Liter (16 Gallon) Platens

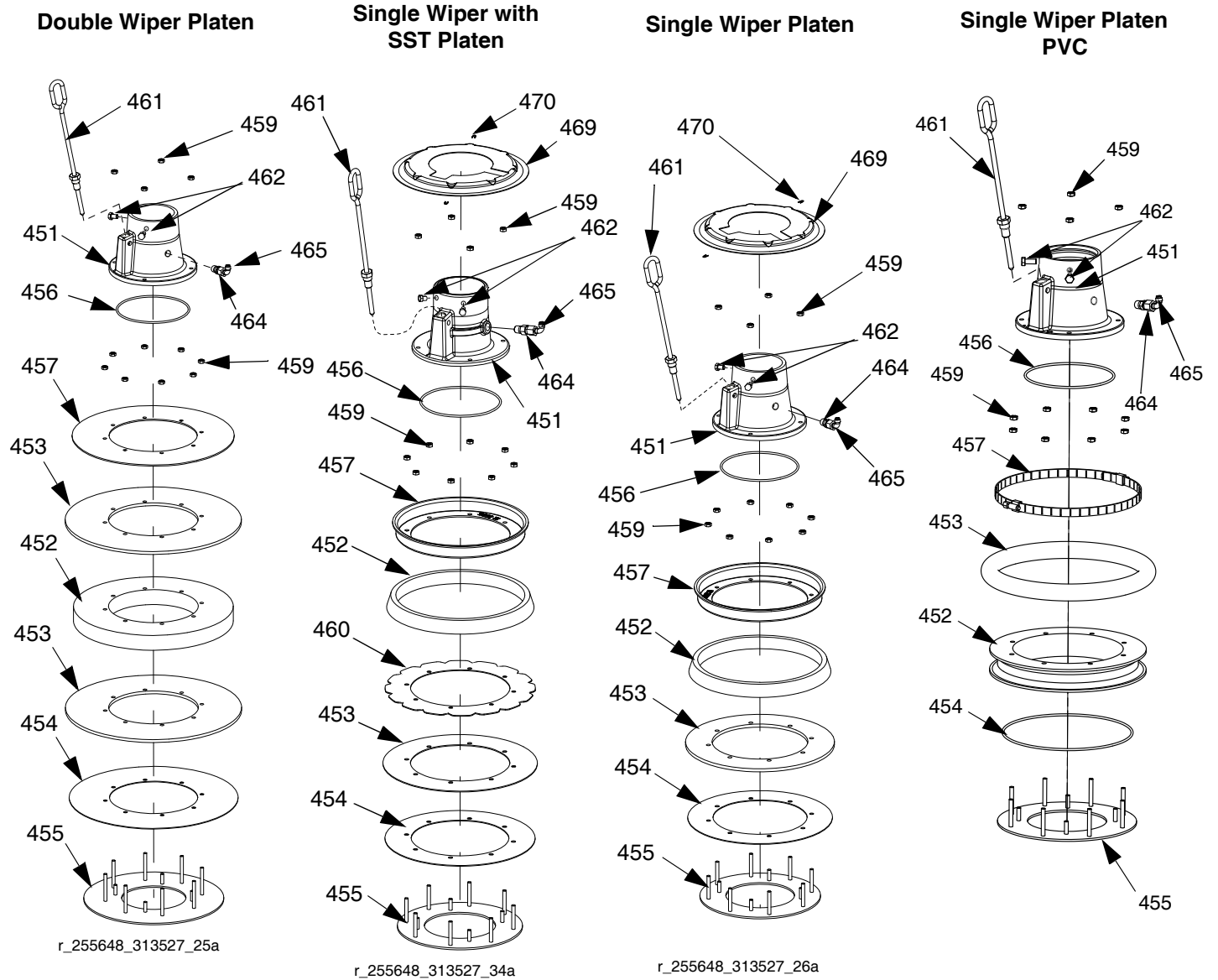

FIG. 35: Single and Double Wiper Assemblies

## Platen Descriptions

Platen	Platen Size	Platen Material	Seal Material	Wiper Assembly Kit
257727✳	20 Liter (see page 52)	CS	Nitrile	257639
257728✳		CS	PolyUrethane	257640
257729✳		SST	PTFE-coated Nitrile	257641
257730✳		CS	Nitrile	257642
257731✳		CS	PolyUrethane	257643
25A206✳		SST	Nitrile (FDA Approved)	25A207
25E110✳		CS	PVC	25E111
257732✳	30 Liter (see page 52)	CS	Nitrile	257644
257733✳		CS	PolyUrethane	257645
257734✳		SST	PTFE-coated Nitrile	257646
257735✳		CS	Nitrile	257647
257736✳		CS	PolyUrethane	257648
257737✳	60 Liter (see page 54)	CS	Nitrile	257649
257740✳		CS	PolyUrethane	257650
257738✳		SST	PTFE-coated Nitrile	257651
257739✳		CS	Nitrile	257652
257741✳		CS	PolyUrethane	257653

✳ Single wiper

✳ Double wiper

See page 52-54 for parts.

**Common Parts**

The parts listed below are common among all 20, 30, and 60 liter platens. Parts that vary are found in the tables on page 52-54.

Ref. Part	Description	Qty.
456	121829 O-RING	1
459	555413 NUT, (For SST platens)	12
	113504 NUT, keps, hex hd (For CSTL platens)	12
461	257697 HANDLE, bleed, sst	1
463	109482 O-RING; see page 54	1
465	17E556 FITTING, PTC, elbow, 1/4 NPT, 1/4 TUBE	1

**Varying Parts - 20 Liter (5 Gallon) Platens**

The following table indicates which parts (according to reference number) are included with each platen.

Ref.	Description	Reference Numbers							Qty:
		257727	257728	257729	257730	257731	25A206	25E110	
451	BASE	257665	257665	257662	257665	257665	257662	257665	1
452 ‡	SPACER	276049	276049	276049	257694	257694	276049	17T370	1
453 ‡	WIPER, main	257672	257678	257675	257672 (2)	257672 (2)	25A208	15W597	1 (2)
454 ‡	WIPER, PE support	257681	257681	257681	257681	257681	257681	17T371	1
455 ‡	PLATE, bottom	257668	257668	257671	257668	257668	257671	257668	1
457 ‡	PLATE, top - clamp retainer	257692	257692	257698	257686	257686	257698	C31154 (2)	1 (2)
460 ‡	WIPER, support			257689			n/a		1
462 ‡	SCREW, cap, hex hd	100057	100057	112894	100057	100057	112894		2
464	VALVE, check	122056	122056	501867	122056	122056	501867	122056	1
468 ‡	TAG, instructions	n/a	n/a	n/a			n/a	n/a	1
469 ‡	COVER	15W184	15W184	15W184			15W184		1
470 ‡	PIN, hairpin, cotter (10 pack)	16U740	16U740	16U740			16U740		2

Parts designated n/a are not available separately. ‡ See page 51 for wiper assembly kits.

**Varying Parts - 30 Liter (8 Gallon) Platens**

The following table indicates which parts (according to reference number) are included with each platen.

Ref.	Description	Reference Numbers					Qty:
		257732	257733	257734	257735	257736	
451	BASE	257665	257665	257662	257665	257665	1
452 ‡	SPACER	194148	194148	194148	257695	257695	1
453 ‡	WIPER, main	257673	257679	257676	257673 (2)	257679 (2)	1 (2)
454 ‡	WIPER, PE support	257682	257682	257682	257682	257682	1
455 ‡	PLATE, bottom	n/a	n/a	n/a	n/a	n/a	1
457 ‡	PLATE, top	n/a	n/a	n/a	n/a	n/a	1
460 ‡	WIPER, support			257690			1
462 ‡	SCREW, cap, hex hd	100057	100057	112894	100057	100057	2
464	VALVE, check	122056	122056	501867	122056	122056	1
468 ‡	TAG, instructions	n/a	n/a	n/a			1
469 ‡	COVER	15X403	15X403	15X403			1
470 ‡	PIN, hairpin, cotter (10 pack)	16U740	16U740	16U740			2

*Parts designated n/a are not available separately.*  
‡ See page 51 for wiper assembly kits.

### Varying Parts - 60 Liter (16 Gallon) Platens

The following tables indicates which parts (according to reference number) are included with each platen.

Ref.	Description	Reference Numbers					Qty:
		257737	257740	257738	257739	257741	
451	BASE	257665	257665	257662	257665	257665	1
452 ‡	SPACER	257684	257684	257684	257696	257696	1
453 ‡	WIPER, main	257674	257680	257677	257674 (2)	257680 (2)	1 (2)
454 ‡	WIPER, PE support	257683	257683	257683	257683	257683	1
455 ‡	PLATE, bottom	n/a	n/a	n/a	n/a	n/a	1
457 ‡	PLATE, top	n/a	n/a	n/a	n/a	n/a	1
460 ‡	WIPER, support			257691			1
462 ‡	SCREW, cap, hex hd	100057	100057	112894	100057	100057	2
464	VALVE, check	122056	122056	501867	122056	122056	1
468 ‡	TAG, instructions	n/a	n/a	n/a			1
469 ‡	COVER	15X404	15X404	15X404			1
470 ‡	PIN, hairpin, cotter (10pack)	16U740	16U740	16U740			2

▲ Parts designated n/a are not available separately. ‡ See page 51 for wiper assembly kits.

### Platen Mounting Kits

#### Check-Mate Mounting

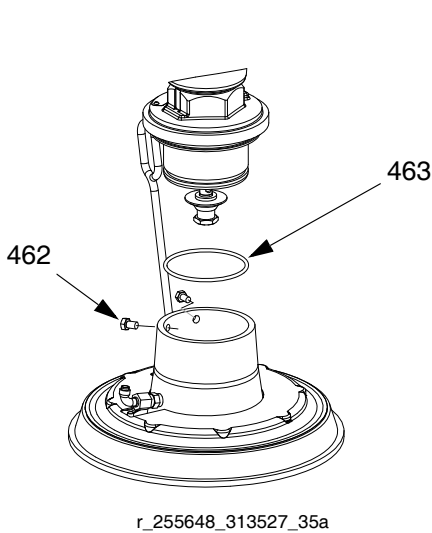

#### Dura-Flo SS Mounting Kit 257630

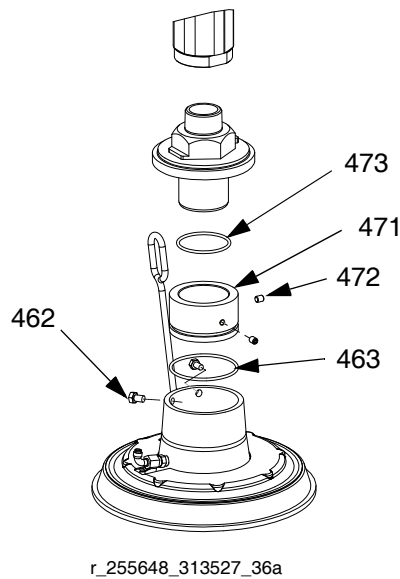

#### Dura-Flo CS Mounting

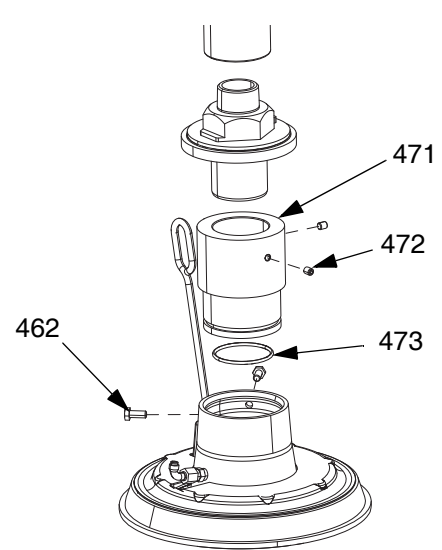

Ref.	Part	Description	Qty.
463	109482	O-RING	1
471		ADAPTER	1
472		SCREW, socket-hd	2
473	109458	O-RING	1

## Kits and Accessories

Accessories are available from Graco. Make certain all accessories are adequately sized and pressure-rated to meet the system's requirements.

### Drum Roller Kits for D200 and D200S Supply Units, 255627

See the Drum Roller Kit manual for more information.

### Drum Position Clamp Set for D200 Supply Units, 206537

Includes two clamps.

### Drum Position Clamp for D200S Supply Units

Order quantity 2 of C32463.

### Enclosed Wet Cup Recirculation Kit

See the Enclosed Wetcup Recirculation Kit manual for more information.

### 200 Liter (55 Gallon) Platen Cover Kits, 255691

See the Platen Cover Kit manual for more information.

### Light Tower Kit, 255468

For D200s, D200, and D60 single supply systems.

See the Light Tower Kit manual for more information.

### ADM Kit, 25E437

Part	Description	Qty.
24E451	MODULE, gca, adm	
124415	CABLE, 5 pin	
261105	TIE, cable	
15M121	TOKEN, gca, key	

### CAN Cables

The following CAN cables and splitter are available for use with E-Flow SP electric pumps.

Part	Description	Length
125306	CABLE, CAN, female/female	0.3 m
123422	CABLE, CAN, female/female	0.5 m
121000	CABLE, CAN, female/female	0.5 m
121227	CABLE, CAN, female/female	0.6 m
121001	CABLE, CAN, female/female	1.0 m
121002	CABLE, CAN, female/female	1.5 m
121003	CABLE, CAN, female/female	3.0 m
120952	CABLE, CAN, female/female	4.0 m
121201	CABLE, CAN, female/female	6.0 m
121004	CABLE, CAN, female/female	8.0 m
121228	CABLE, CAN, female/female	15.0 m
123341	CABLE, CAN, female/female	40.0 m
121807	CONNECTOR, splitter, male/male	

### I/O Cable, 122029

See the E-Flo SP Software Instructions manual for setup and pin out information.

Part	Description	Length
122029	CABLE, GCA, M12-8p	15.0 m

## Communication Gateway Module (CGM) Kits

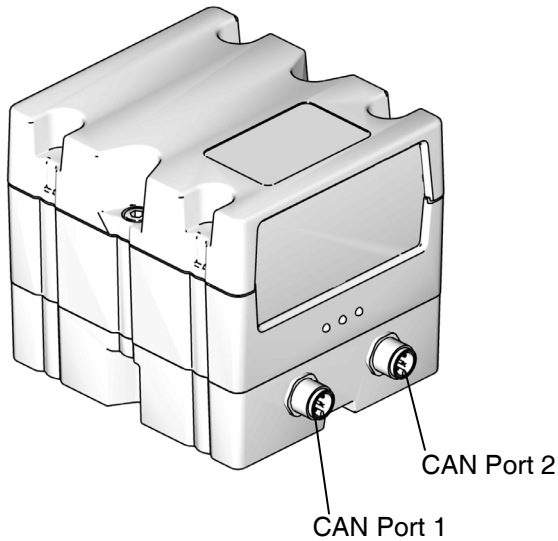

FIG. 36: CGM CAN Connections

### CGM Kits

Part Number	Description
25E426	CGM Kit, Ethernetip
25E427	CGM Kit, DeviceNet
25E428	CGM Kit, PROFINET
25E429	CGM Kit, PROFIBUS

### Installing a CGM Kit

All electrical wiring must be done by a qualified electrician and comply with all local codes and regulations

1. Follow the **Pressure Relief Procedure** on page 22.
2. Verify the power is off to the system.
3. Mount the CGM near the pump or near the integration point.

4. Drill the mounting holes using the mounting hole dimensions shown in FIG. 37.

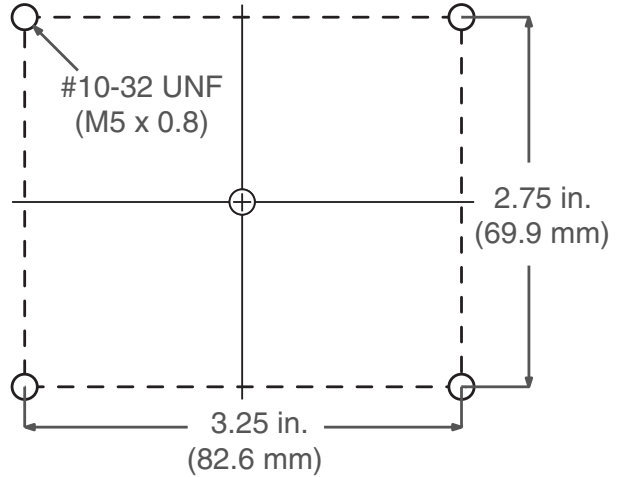

FIG. 37: CGM Mounting Holes

5. Remove the access cover from the CGM (CA). Loosen the two screws (CB) and remove the CGM (CC) from the base (CD) as shown in FIG. 38.

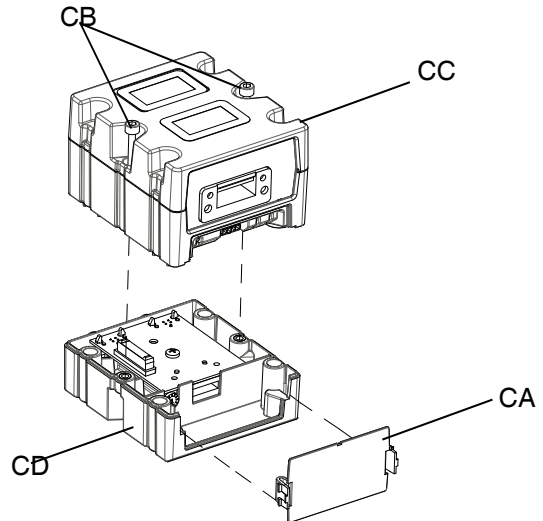
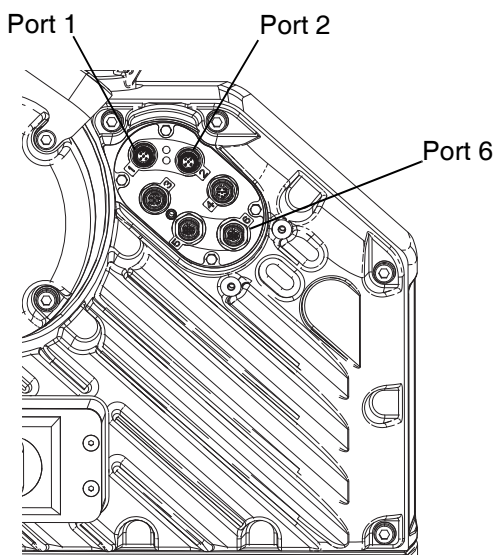

FIG. 38: Disassembling the CGM

6. Using the four 10-32 mounting screws included with the kit, mount the base (CD) in the holes you drilled.
7. Reattach the CGM (CC) on the base (CD) with the two screws (CB) that were removed in step 5.
8. Reattach the access cover (CA).



9. Connect the CAN cable included in the kit to either port 1 or port 2 (whichever is available) on the driver. See FIG. 39.

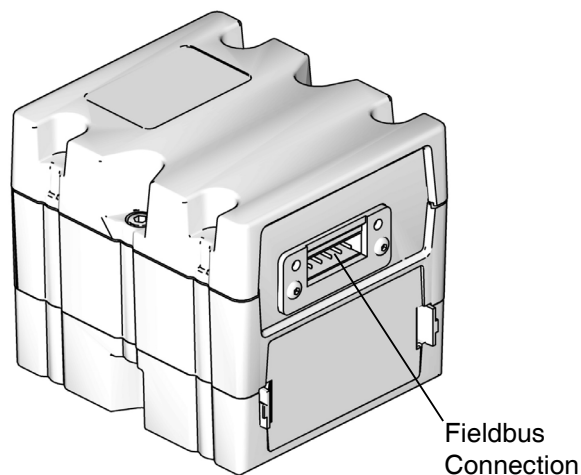

**FIG. 39: Driver Port Locations**

10. Connect the other end of the CAN cable to either CAN port 1 or 2 on the CGM. See FIG. 36. It can be connected to either port.

**NOTE:** Longer CAN cables, if required, are available from Graco. See **CAN Cables** on page 55.

11. Connect the Ethernet, DeviceNet, or PROFIBUS cable to the fieldbus connection on the CGM as applicable. See FIG. 40.



**FIG. 40: CGM Fieldbus Connection**

12. Connect the other end of the cable to the fieldbus device.
13. Refer to the Graco Control Architecture Module Programming manual for step-by-step instructions on how to update the software version of GCA modules. See **Related Manuals** on page 3.
14. Refer to the E-Flo SP Software Instructions manual for details regarding the fieldbus pinout setup and to perform the setup procedure to configure the fieldbus. See **Related Manuals** on page 3.

## Low Level Sensor Kit, 25E447

To install the Low Level Sensor:

1. Turn the disconnect switch (M) OFF.
2. Disconnect cable from the empty level sensor (EL).
3. Mount the low level sensor (LL) on the mounting bracket.
4. Connect the shorter cable to the low level sensor (LL).
5. Connect the other shorter cable to the empty level sensor (EL).
6. Connect the low level sensor cable to the A port on the splitter (SP).
7. Connect the empty level sensor cable to the B port on the splitter (SP).
8. Connect the original cable to the last port on the splitter (SP).
9. Raise/lower the low level sensor (LL) to the desired position to activate the sensor.
10. See the E-Flo SP Software Instructions manual to set up the low level sensor.

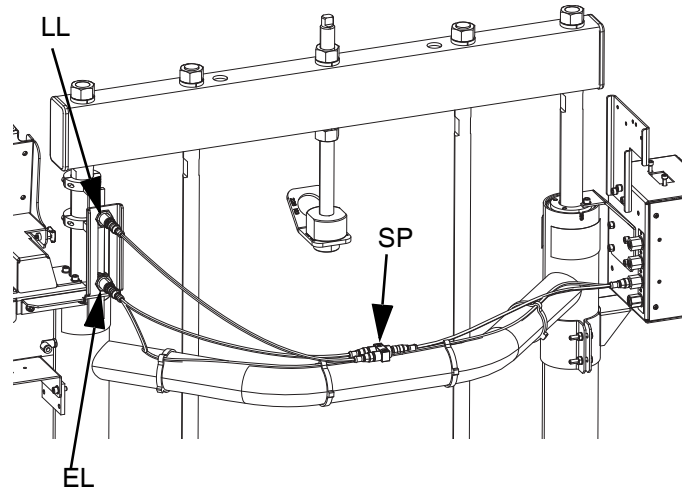
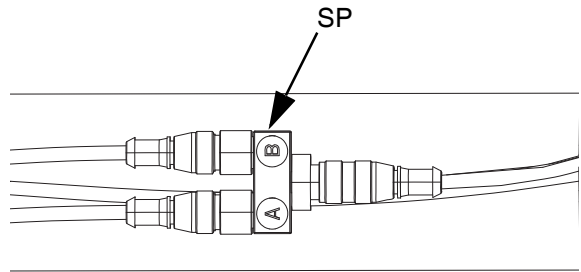

# Tandem Connection Kit, 25E595

Ref.	Part	Description	Qty.
501	121226	CABLE, can, 0.4 m	1
502	124003	CABLE, can, 5.0 m	1
503	121003	CABLE, can, 3.0 m	1
504	121807	CONNECTOR, splitter	1
505	114958	STRAP, tie	3
506	117329	STRAP, tie	6

To install the Tandem Connection Kit:

1. On the primary tandem unit (Ram 1), connect the cable (501) from port C1 to the splitter (504).

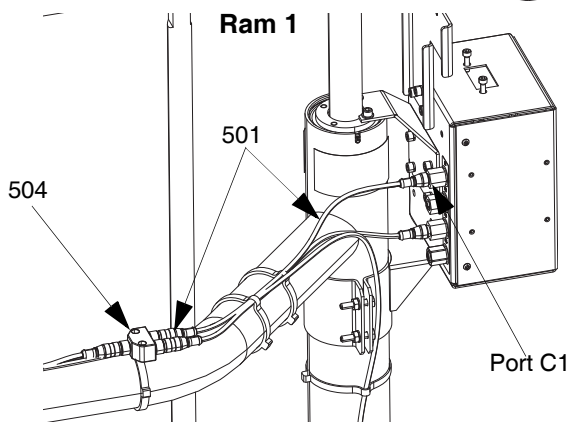
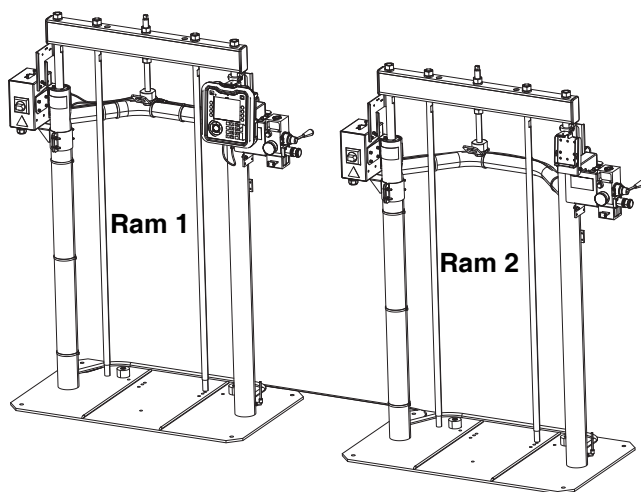

2. Connect the other cable (503) from the splitter to the ADM. Run the cable along the back of the ram using wire ties (505) to secure to the tubing.

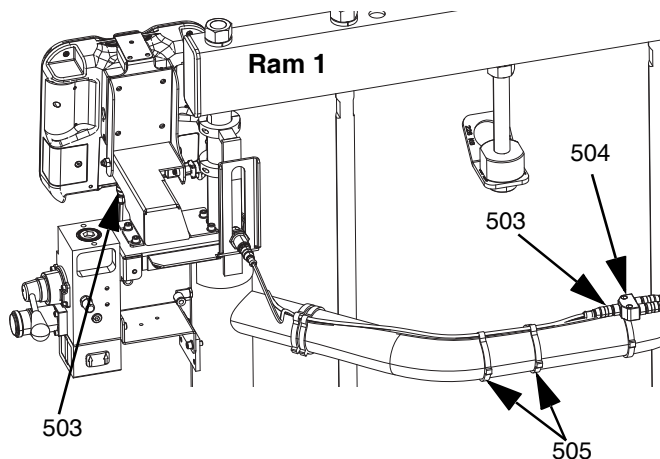

3. Connect the cable (502) from the splitter to port C2 on the secondary tandem unit (Ram 2) junction box.

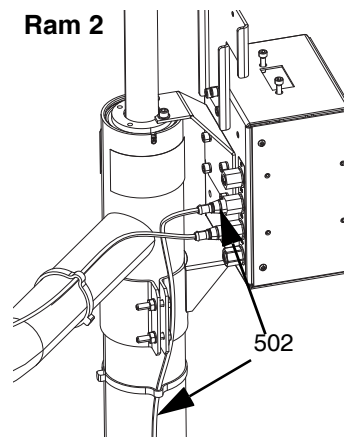
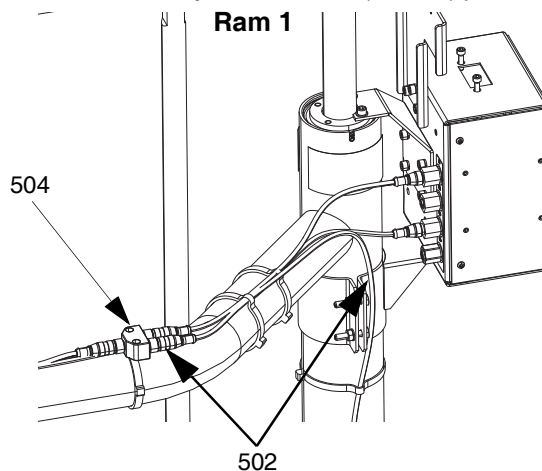

4. See the E-Flo SP Software Instructions manual for system setup.

## Tandem Depressurization/Recirculation Kit, 25E618 (carbon steel), 25E619 (stainless steel)

Ref. Part	Description	Qty.
601	C20487 FITTING, nipple, hex (25E618 only)	1
	190724 NIPPLE, sst (25E619 only)	
602	132019 FITTING, tee, 3/4 npt (25E618 only)	1
	15M862 FITTING, tee, pipe (25E619 only)	
604	15B556 FITTING, adapter, 1/4 npt x 3/4 npt	1
605	156648 ADAPTER, swivel, straight (25E618 only)	1
	15M859 FITTING, adapter, male, swivel (25E619 only)	
606	054753 TUBE, nylon, black	22.5 ft
607	25R844 VALVE, 25, npt/b,000rm,amb,5k	1
609	255722 HOSE, coupled, hp (25E618 only)	1
	255725 HOSE, coupled, hp, sst (25E619 only)	
610	517434 FITTING, tee, 1/2 npt	1
613	15M574 VALVE, solenoid	1
614	117820 SCREW, cap, socket hd	2
615	198178 FITTING, elbow	3
616	17Z412 BRACKET, valve, solenoid	1
617	107100 SCREW, cap	2
618	18A098 HARNESS, solenoid, tandem PKG	1
619	116504 FITTING, tee	1
620	070408 SEALANT, pipe, sst	1
621	114958 STRAP, tie	4
624	114151 FITTING, elbow, male, swivel	2

To assemble the Tandem Depressurization/Recirculation Kit:

1. Disconnect the air line from the air assist body check valve (EH).
2. Remove the bleed stick (EF) and bleed port (EG). Save all parts for later.

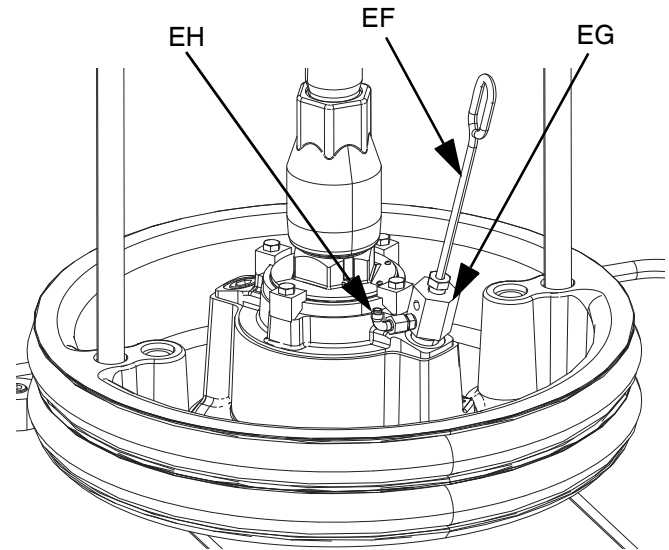

3. Assemble the fittings and valve onto the platen as shown below.

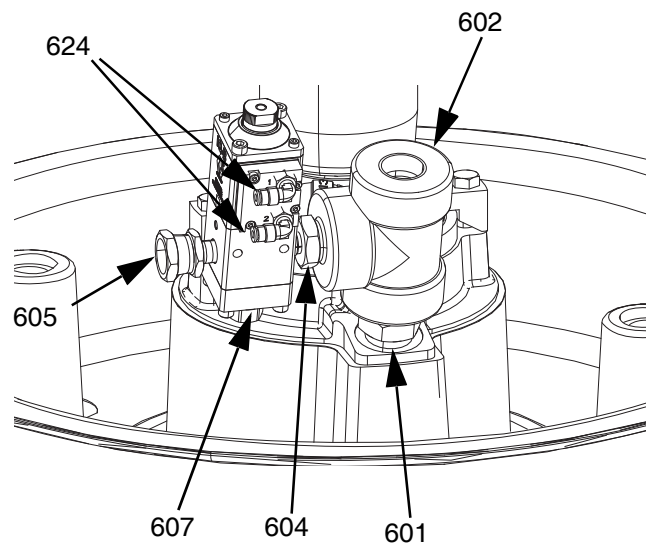

- Assemble the bleed port (EG) and bleed stick (EF) to the cross fitting (602).

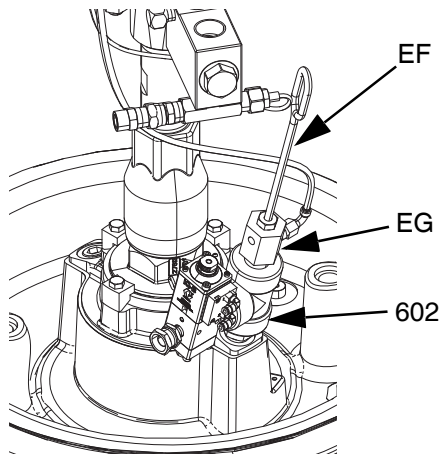

- Connect the cable (618) from the solenoid (613) to Port 4 on the driver.

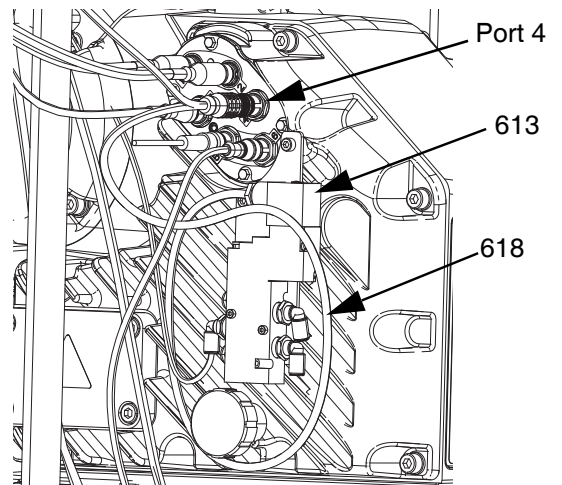

- Mount the solenoid mounting plate (616) to the side of the driver using the supplied screws (617).

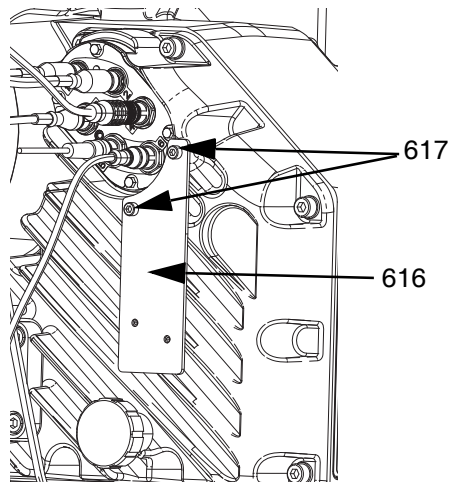

- Remove the adapter and pressure transducer from the bottom of the check valve block.

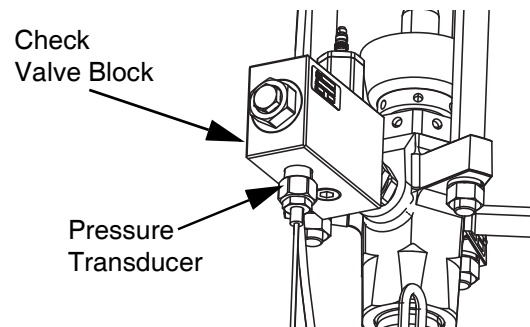

- Mount the solenoid (613) to the solenoid mounting plate (616) with the supplied screws (614).

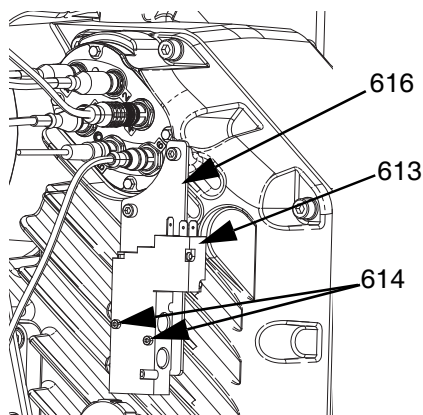

- Connect the tee fitting (614) to replace the adapter and pressure transducer removed in the previous step.

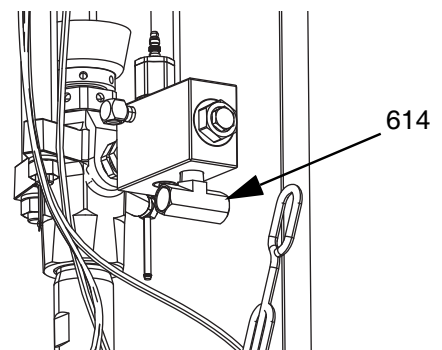

10. Looking at the valve check block from the front, connect the adapter and pressure transducer that were removed in step 8 to the connection on the right side of the tee fitting (610). Connect a union adapter fitting (605) to the other side of the tee fitting.

11. Connect the hose (609) between the fitting (605) above to the fitting (605) in the valve.

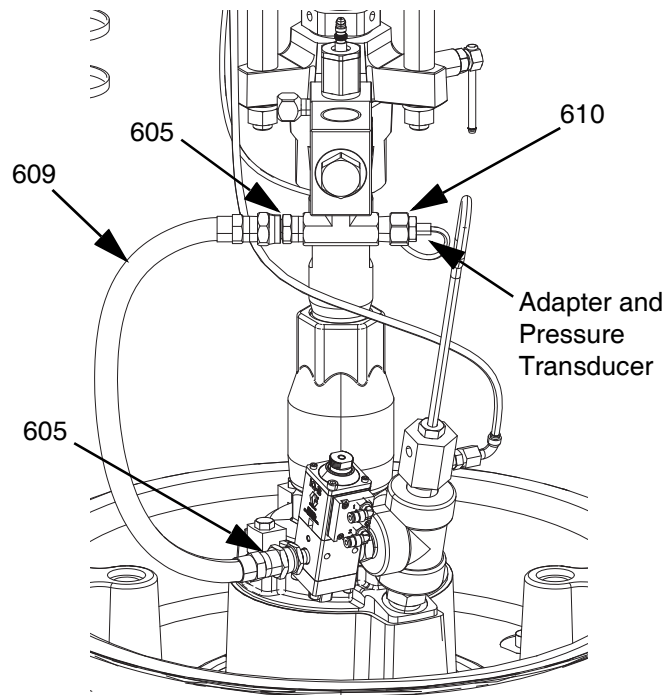

12. Install the fittings (611, 615) on the back of the integrated air control module (G).

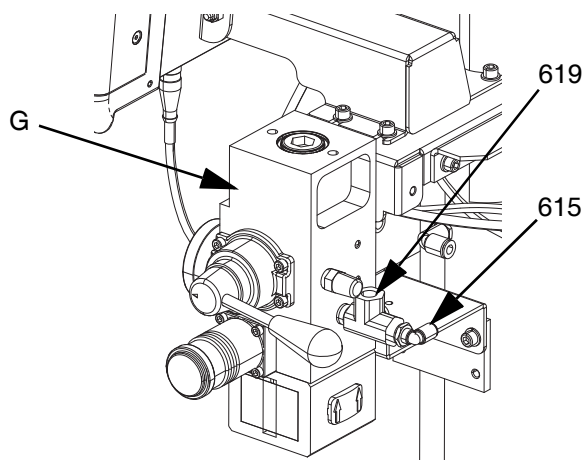

13. Install the air line (606) from the integrated air control module (G), along the back of the ram, through the cable track and to the solenoid (613).

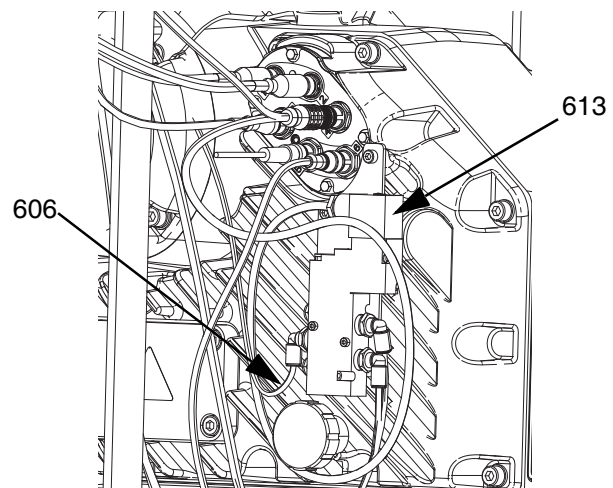
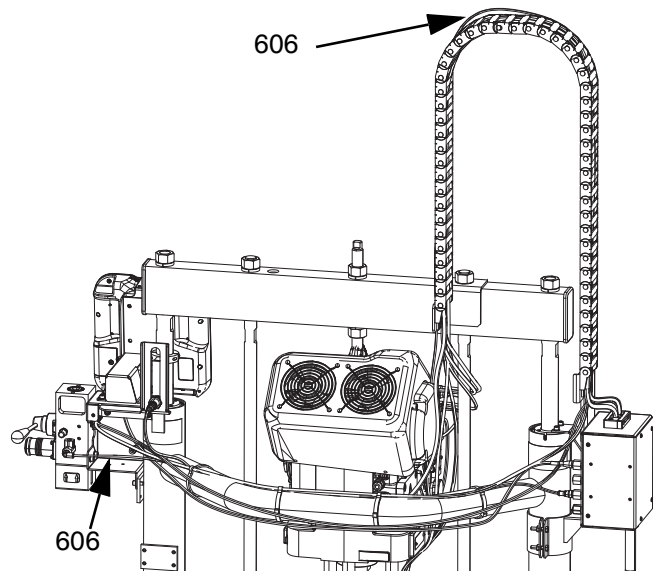
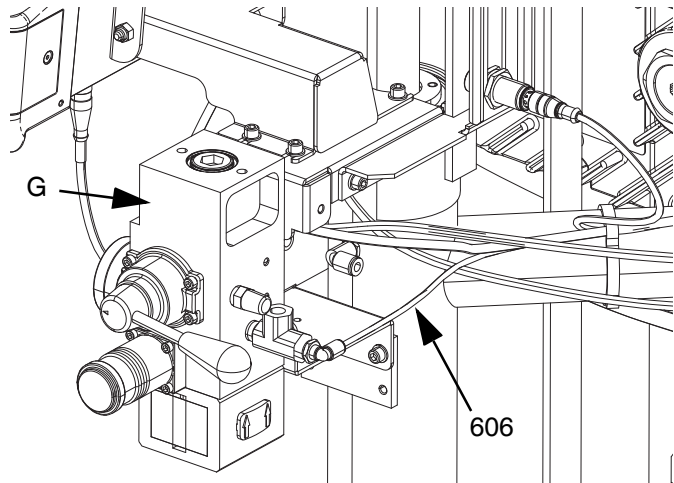

14. Install the air line (606) from the lower solenoid outlet to the valve close fitting (615). Cut any excess air line.
15. Install the air line (606) from the upper solenoid outlet to the valve open fitting (615). Cut any excess air line.

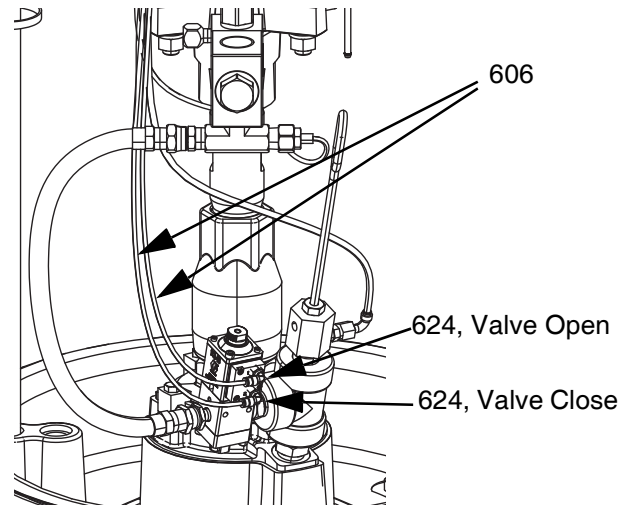
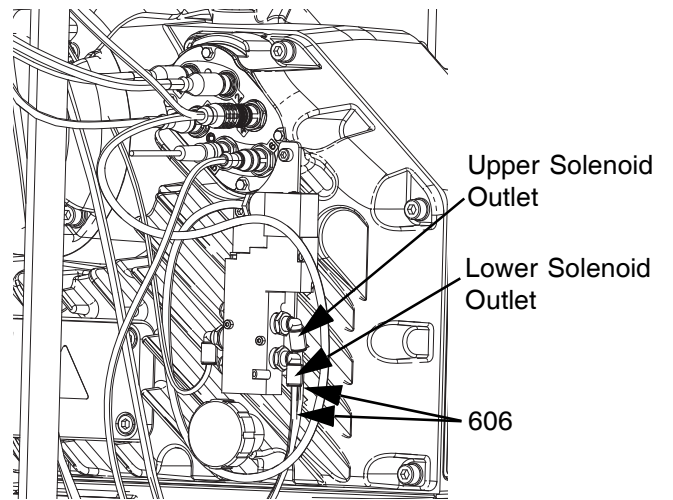

16. See the E-Flo SP Software Instructions manual for Depressurization/Recirculation setup.

## Tandem Fluid Filter Kit, 25E620

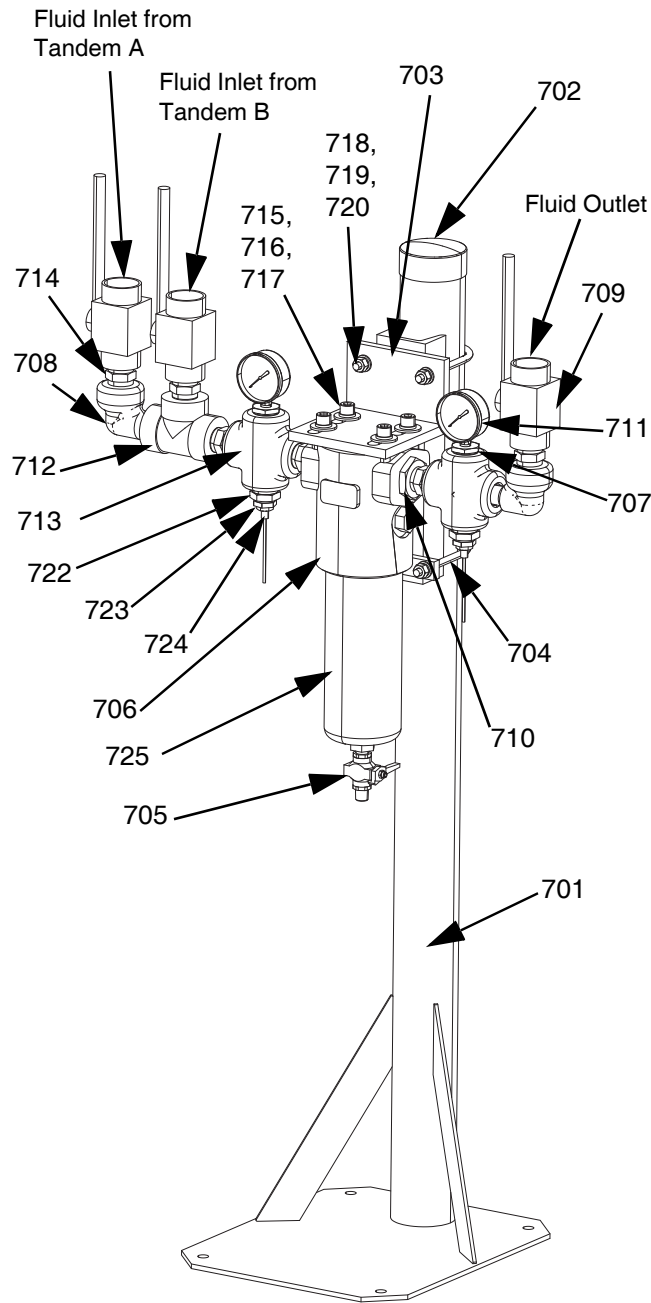

Ref.	Part	Description	Qty.
701	247498	SUPPORT, stand	1
702	410178	CAP PLUG, vinyl	1
703	147499	BASE, mounting	1
704	C30021	BOLT, u	2
705	210658	VALVE, ball	1
706	515216	HOUSING, filter	1
707	C19652	FITTING, bushing, reducing	2
708	121189	FITTING, elbow, 1"	2
709	521477	VALVE, ball, 1"	3
710	121182	ADAPTER, pipe, female	2
711	102814	GAUGE, press, fluid	2
712	C19488	FITTING, tee	1
713	121163	FITTING, cross, 1" npt	2
714	131526	FITTING, nipple, 1" npt, cs	6
715	101044	WASHER, plain	4
716	100018	WASHER, lock, spring	4
717	C19853	SCREW, cap, socket hd	4
718	100023	WASHER, flat	4
719	100133	WASHER, lock, 3/8	4
720	100131	NUT, full hex	4
721	070408	SEALANT, pipe, sst	1
722	158586	FITTING, bushing	2
723	16U440	ADAPTER, fitting, pressure sensor	2
724	15M669	SENSOR, pressure, fluid outlet	2
725	515222	ELEMENT, filter	1
726	15Y048	CABLE, M12	2

To assemble the Tandem Fluid Filter Kit:

1. Ensure the base of the fluid filter stand (701) is level in all directions. If necessary, use metal shims to level the base.
2. Secure the base to the floor using anchors that are long enough to prevent the filter stand from tipping.
3. Install the material hose from tandem A to fluid inlet A.
4. Install the material hose from tandem B to fluid inlet B.
5. Install the material hose from the fluid filter outlet to the dispense valve.
6. Connect the inlet fluid filter pressure transducer to Port 6 on the tandem A driver for fluid filter monitoring.



7. Connect the inlet fluid filter pressure transducer to port 6 on the tandem B driver for fluid filter monitoring.

a. Available extension cables are shown in the table below.

Part	Description
122497	CABLE, M12, 5 pin, 2 m
124409	CABLE, M12, 5 pin, 3 m
124943	CABLE, M12, 5 pin, 1 m
17H363	CABLE, M12, 5 pin, 7.5 m
17H364	CABLE, M12, 5 pin, 16 m

8. See the E-Flo SP Software Instructions manual to set up fluid filter monitoring on the ADM.

### Fluid Filter Kit Dimensions

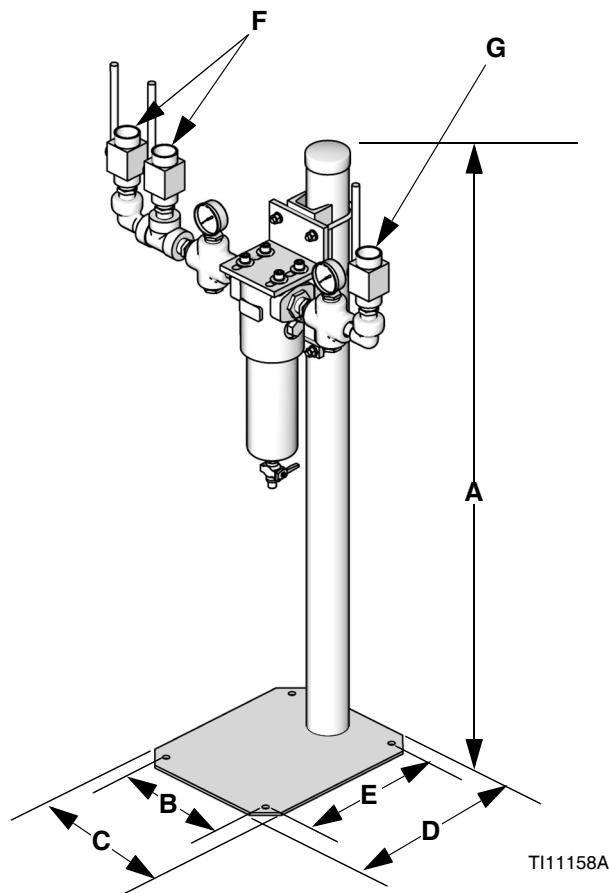

### Key

A	52.25 in. (1327 mm)
B	11 in. (279 mm)
C	14 in. (356 mm)
D	17 in. (432 mm)
E	14 in. (356 mm)
F	1 in. npt(f)
G	1 in. npt(f)

### Filter Element Mesh Sizes

Part No.	Mesh
515219	60
515220	50
515221	40
515222	30 (standard)



# Dimensions

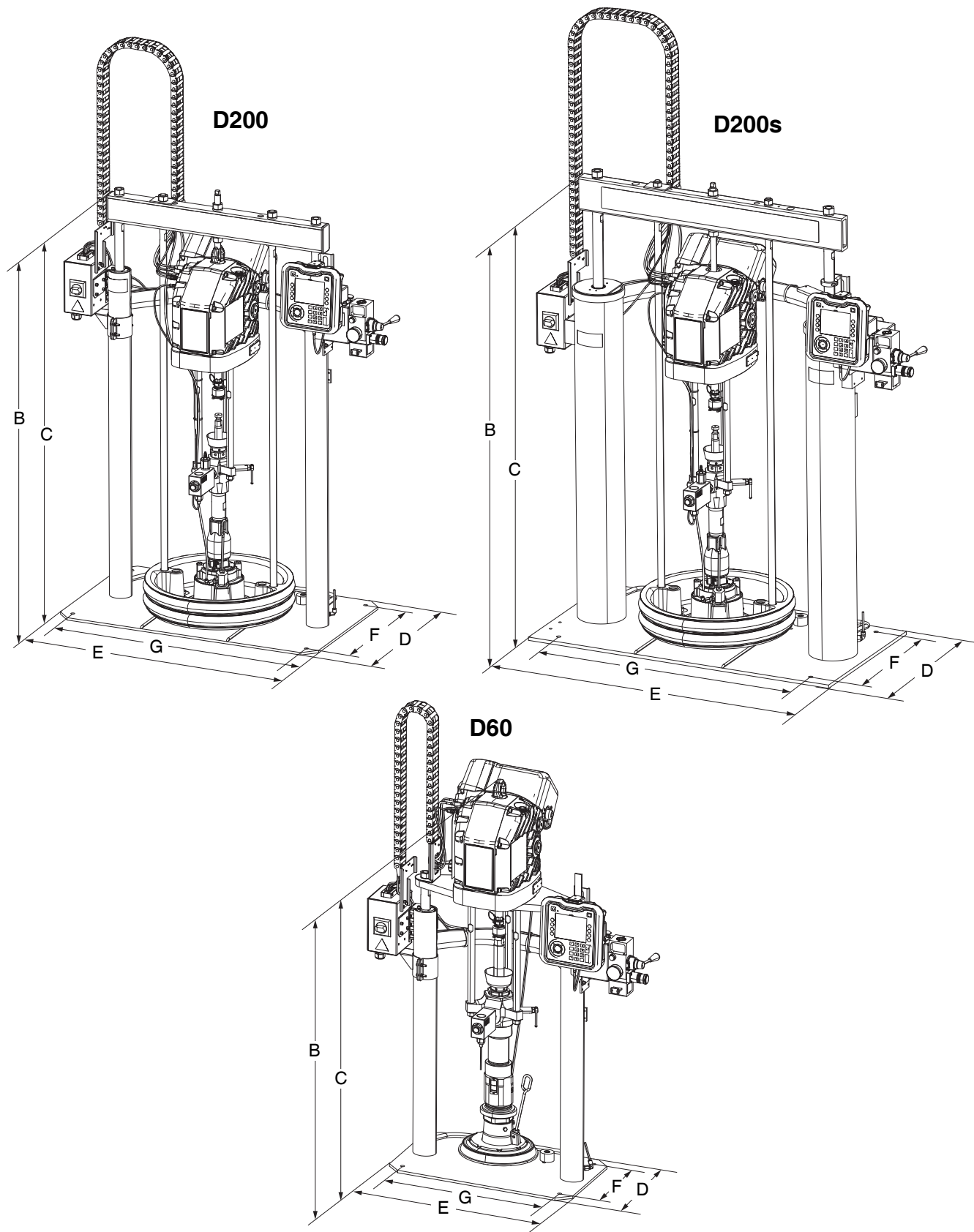

## Dimensions

	Ram Size in. (mm)		
	D60	D200	D200s
<b>Total Height (A)</b>	70 (1778)	88 (2235)	96 (2438)
<b>Ram Height (B)</b>	57 (1448)	63 (1600)	69 (1753)
<b>Extended Ram Height (C)</b>	89 (2261)	118 (2997)	125 (3175)
<b>Base Depth (D)</b>	20 (508)	25 (635)	25 (635)
<b>Machine Width (E)</b>	45 (1143)	55 (1397)	64 (1626)
<b>Mounting Hole Depth (F)</b>	14 (356)	21 (533)	23 (584)
<b>Mounting Hole Width (G)</b>	24 (610)	38 (965)	45 (1143)

## Weight

Use the table below to identify the maximum weight for each available platen size.

Platen Size Gallons (Liters)	Maximum Weight
<b>55 (200)</b>	51 (23)
<b>30 (115)</b>	44 (20)
<b>16 (60)</b>	25 (11.3)
<b>8 (30)</b>	21 (9.5)
<b>5 (20)</b>	19 (8.7)

See the identification plate (ID) for the weight of your supply system.

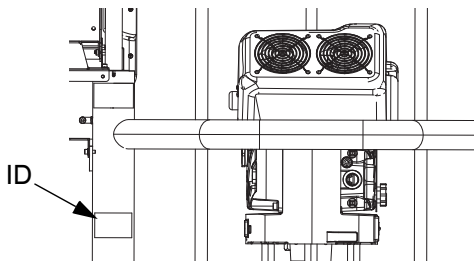

# Pump Performance

## Calculate Fluid Outlet Pressure

To calculate fluid outlet pressure (psi/MPa/bar) at a specific fluid flow (gpm/lpm) and electrical power (W), use the following instructions and pump data chart.

1. Refer to the desired flow along the bottom of the chart.
2. Follow the vertical line up to the intersection with the selected fluid outlet pressure curve. Follow left to the scale to read the fluid out pressure.

## Calculate Electrical Power

To calculate electrical power (W) at a specific fluid flow (gpm/lpm), use the following instructions and pump data chart.

1. Refer to the desired flow along the bottom of the chart.
2. Follow the vertical line up to the intersection with the selected electrical power curve. Follow right to the scale to read the fluid out pressure.

**NOTE:** Performance is measured using 10 weight oil. System design and material being pumped may produce different results.

## E-Flo SP Performance Charts

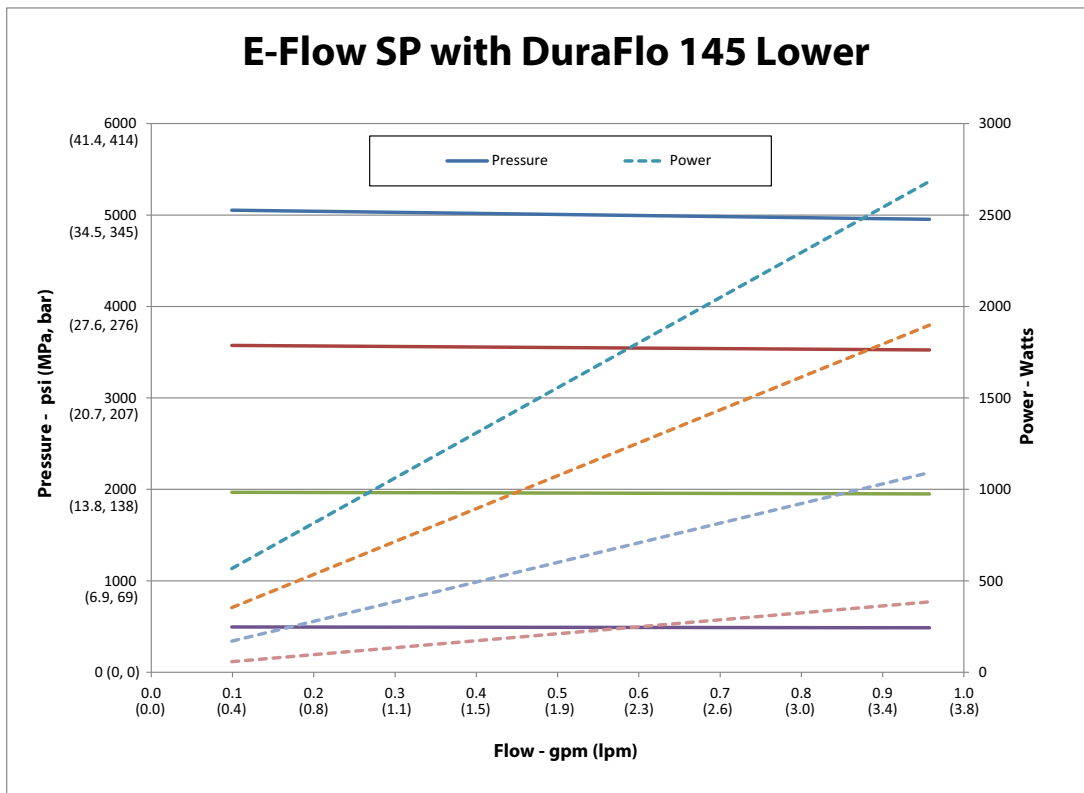
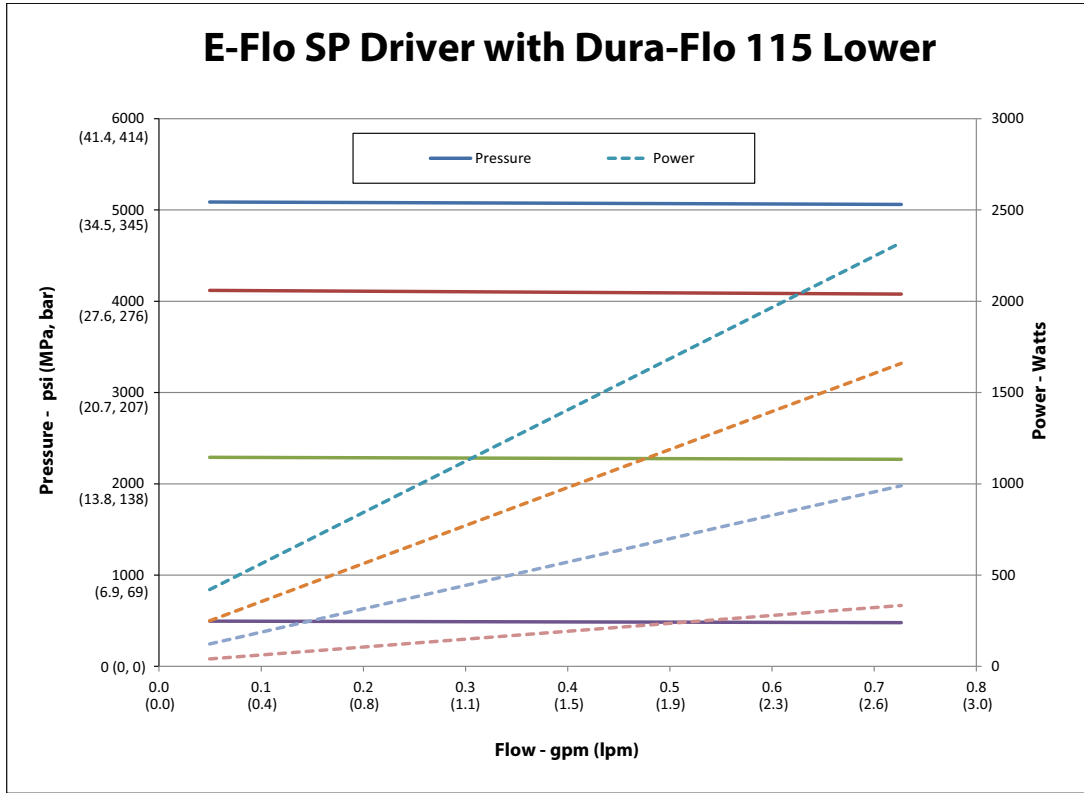

**NOTE:** Performance is measured using 10 weight oil. System design and material being pumped may produce different results.

Pump Performance

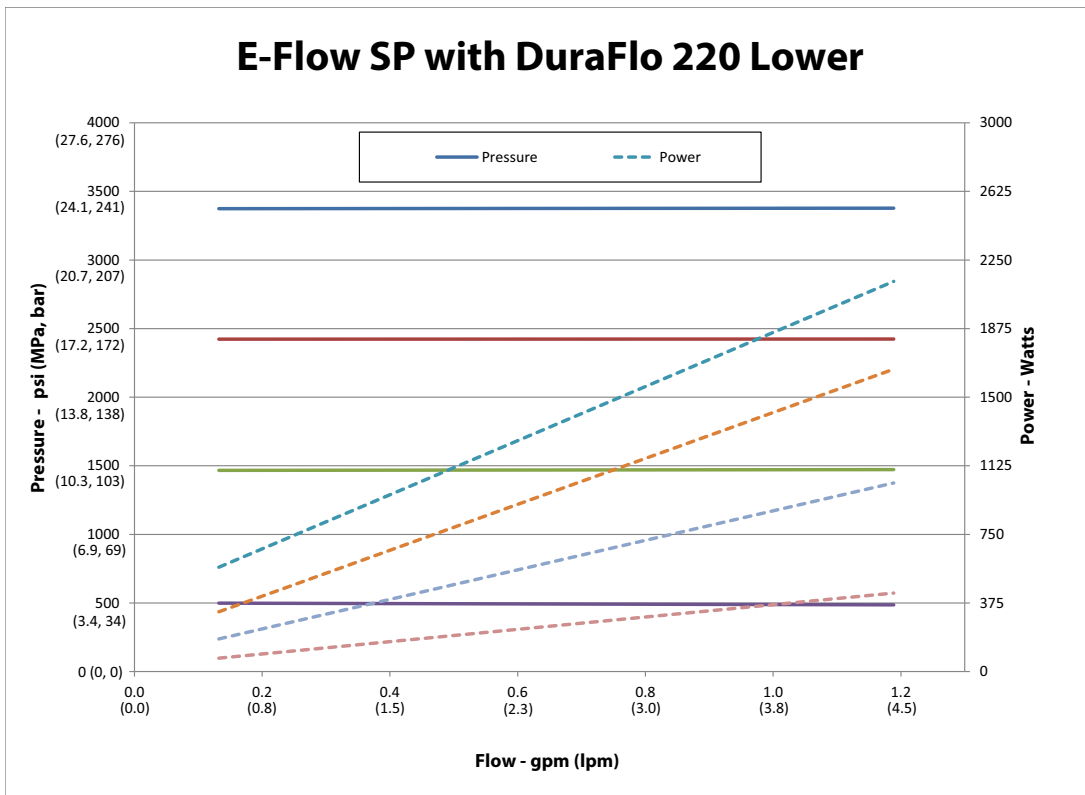
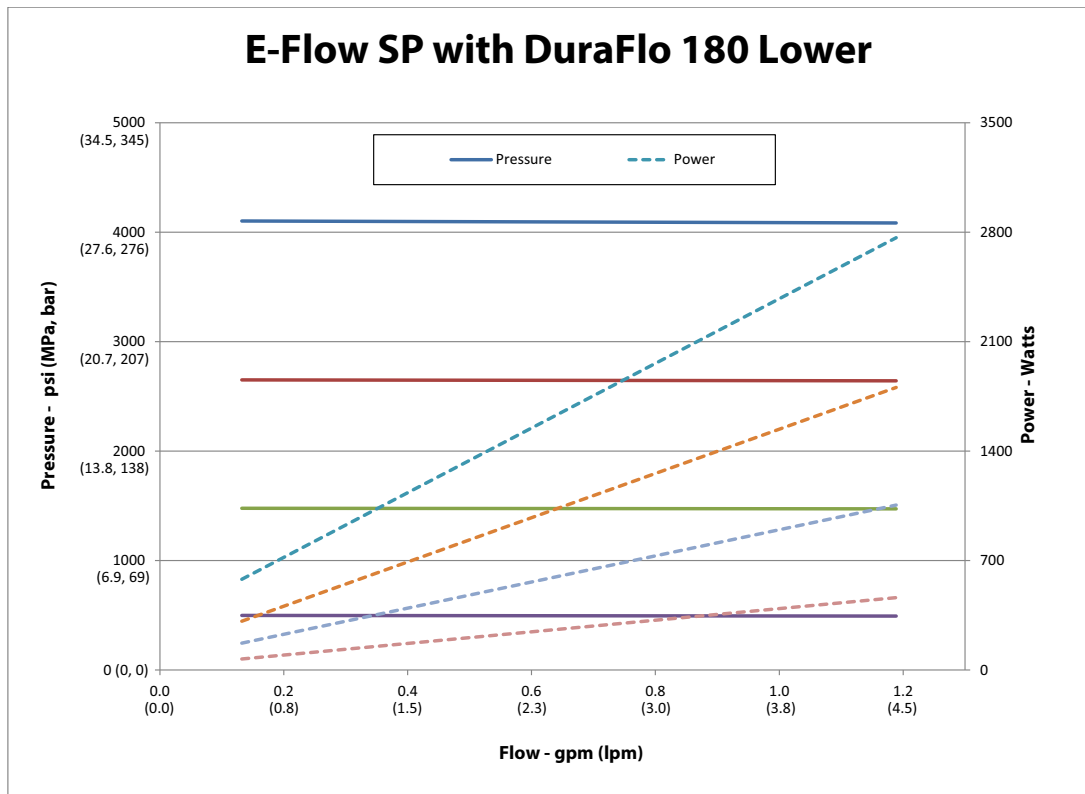

**NOTE:** Performance is measured using 10 weight oil. System design and material being pumped may produce different results.



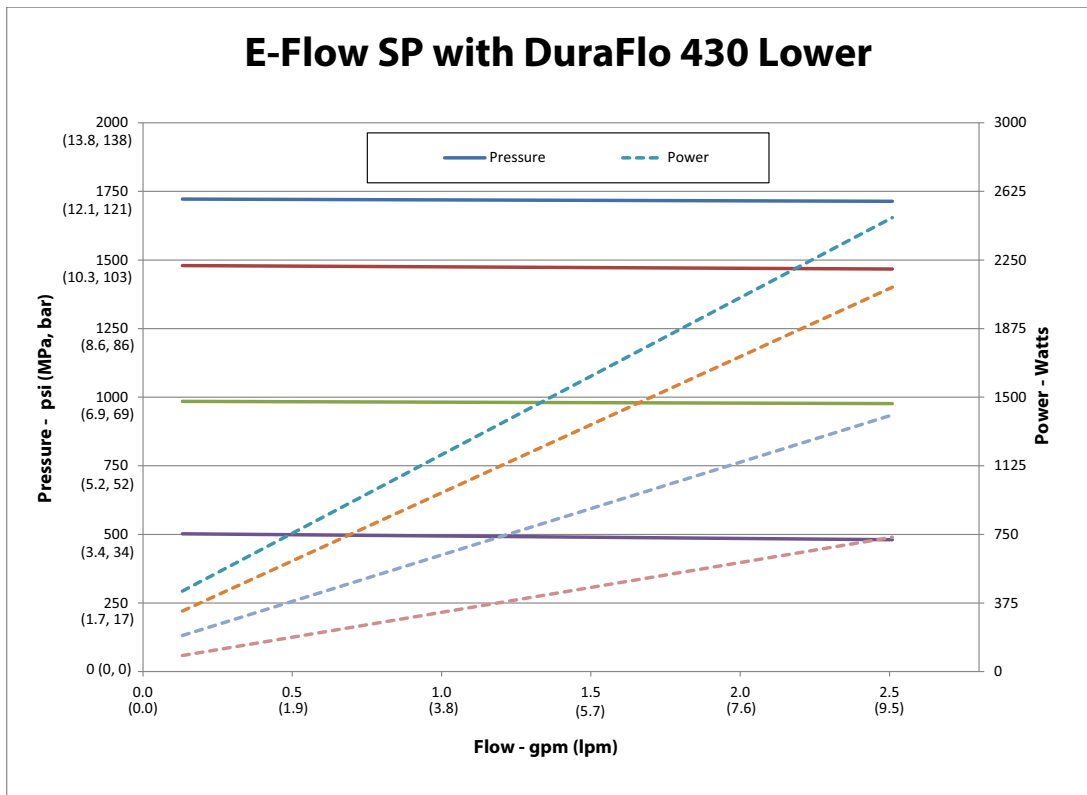
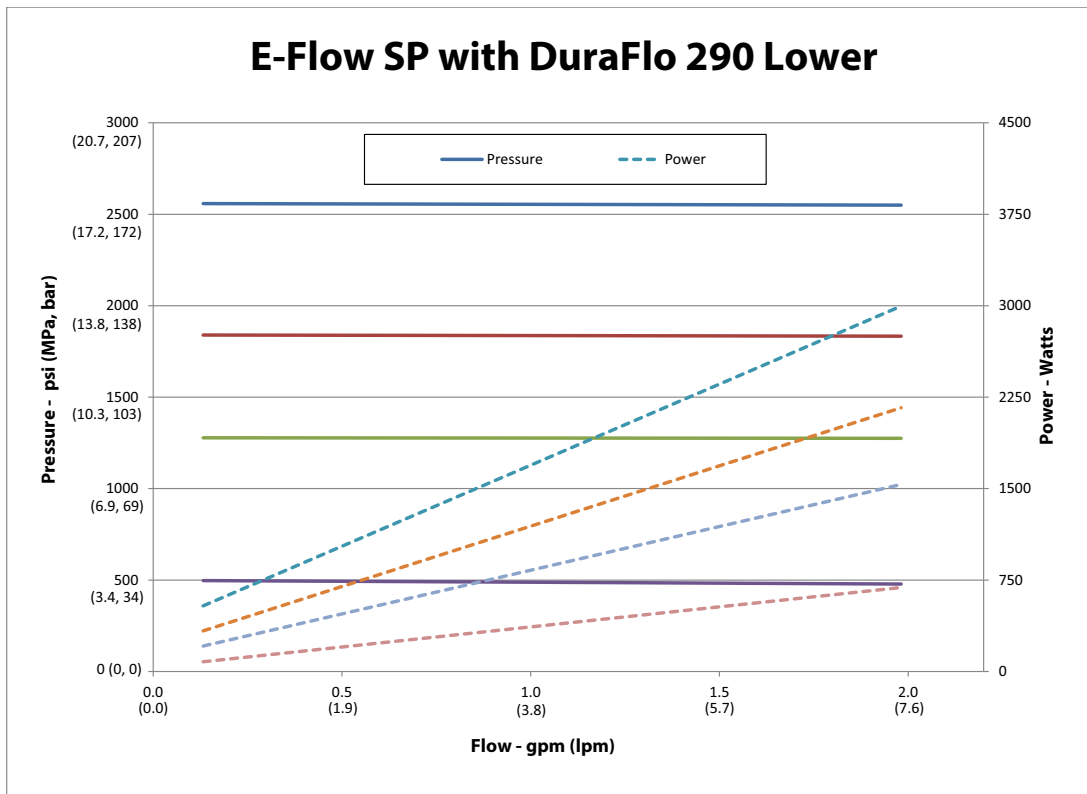

**NOTE:** Performance is measured using 10 weight oil. System design and material being pumped may produce different results.

Pump Performance

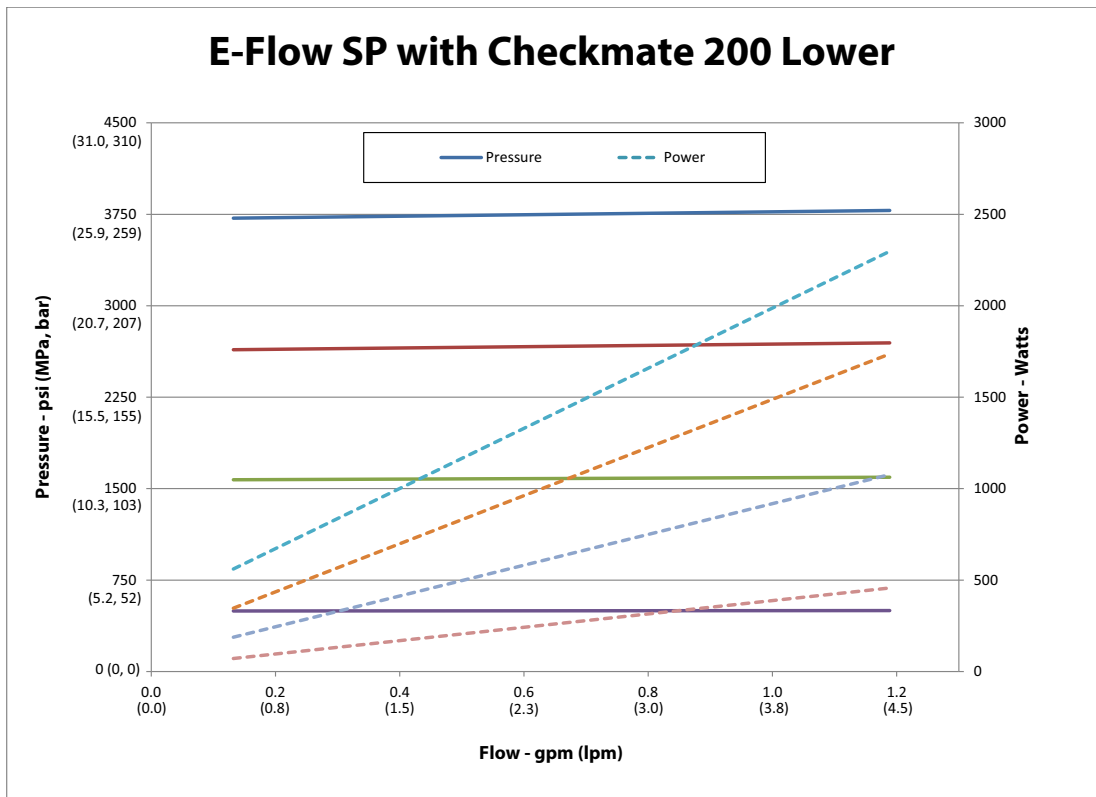
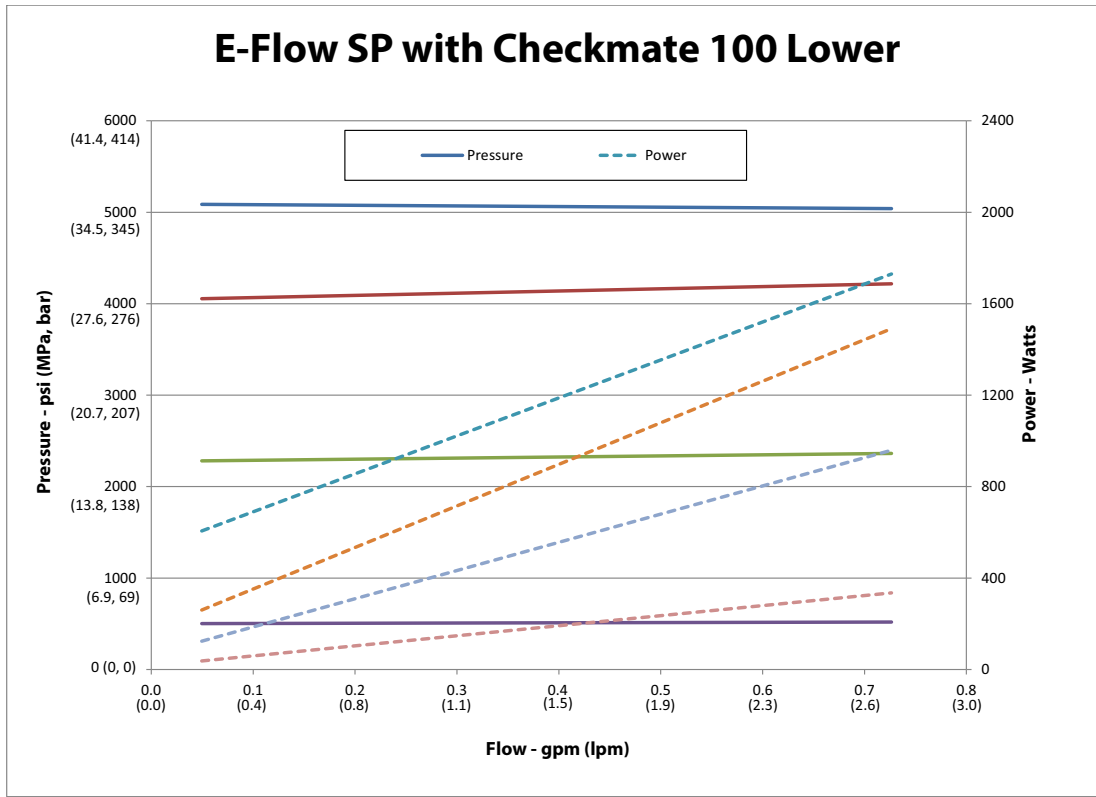

**NOTE:** Performance is measured using 10 weight oil. System design and material being pumped may produce different results.

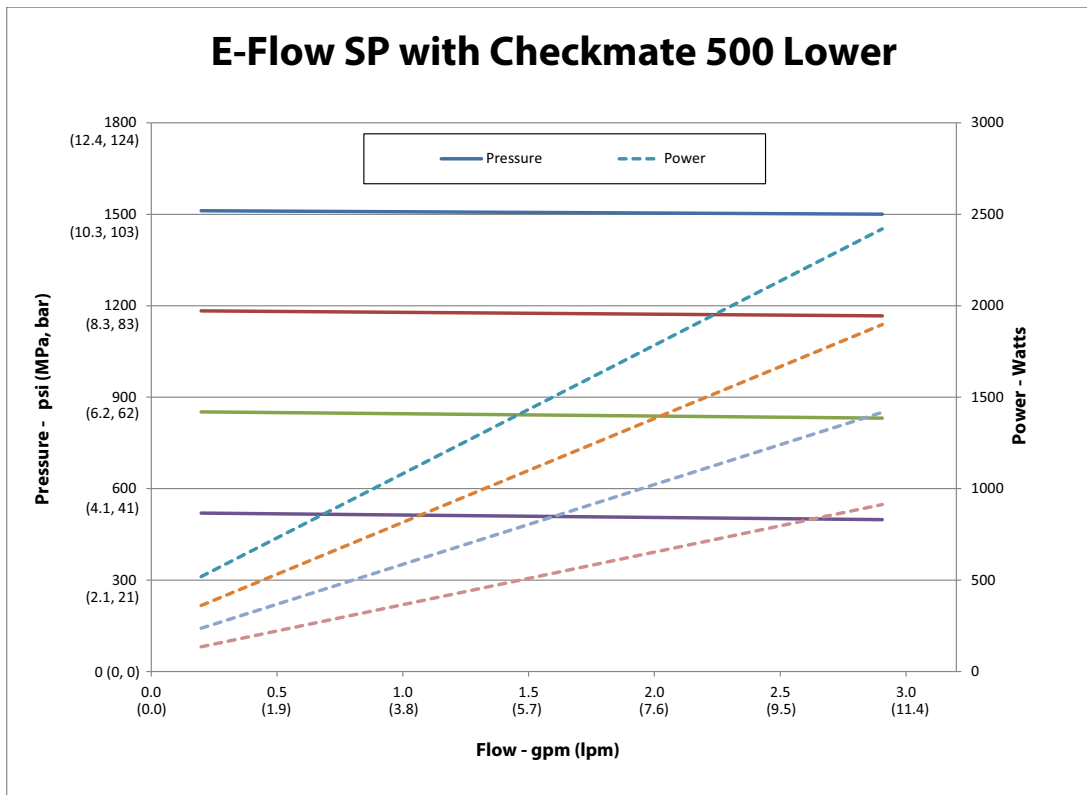
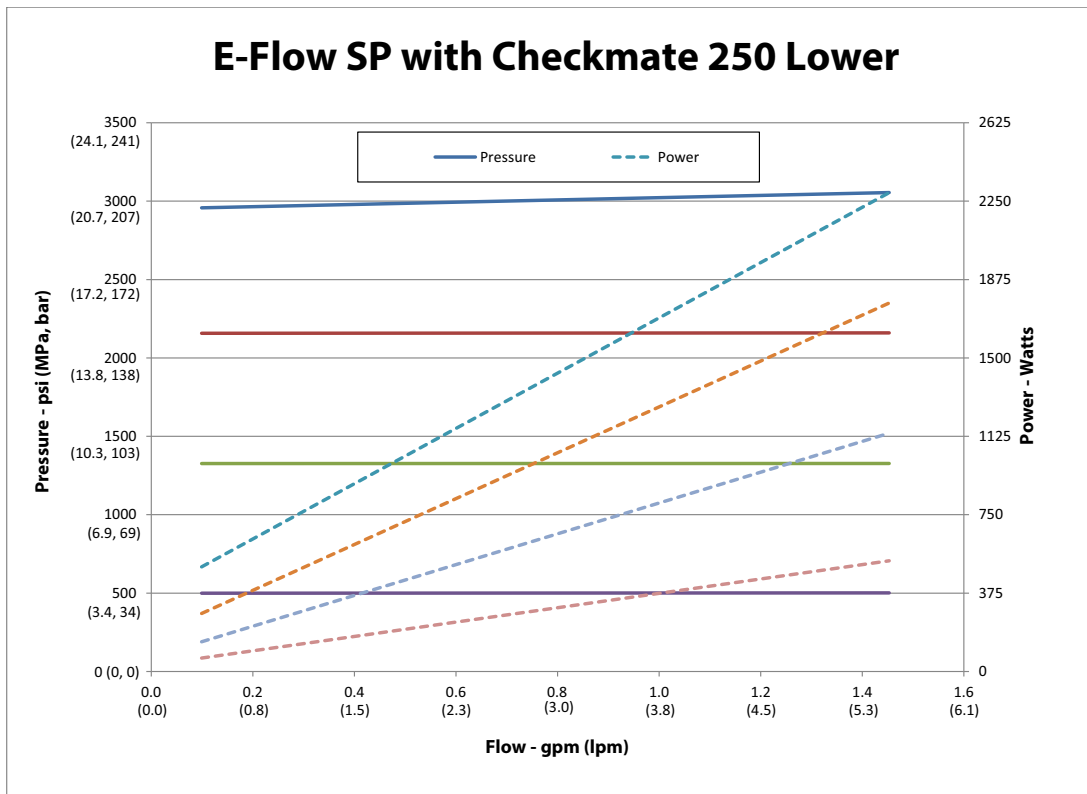

**NOTE:** Performance is measured using 10 weight oil. System design and material being pumped may produce different results.

# Technical Specifications

<b>E-Flo SP Supply Systems</b>		
	<b>US</b>	<b>Metric</b>
Driver thrust	4,840 lbs	2,195 kg
Stroke length	4.75 in.	120.65 mm
Maximum fluid operating temperature	180°F	82.3°C
Maximum driver cycle rate	25 cycles per minute	
Line voltage rating	200-240V, 1ps, 50/60 Hz	
	400-480V, 1ps, 50/60 Hz	
Air inlet size (supply system)	3/4 npt(f)	
Ambient operating temperature range (supply system)	32-120°F	0-49°C
Displacement pump effective area	See pump manual.	
Wetted parts	See pump manual.	
<b>Sound pressure, measured per EN ISO 11202:2010</b>		
Normal operation (dispensing)	< 70 dBA	
Drum change	77 dBA	
<b>Full load amperage</b>		
240V systems	20A	
480V systems	10A	
<b>Maximum fluid working pressure</b>		
100cc Check-Mate - All	6000 psi	414 bar, 41.4 MPa
200cc Check-Mate - All	4200 psi	290.5 bar, 29.0 MPa
250cc Check-Mate - All	2700 psi	186.1 bar, 18.6 MPa
500cc Check-Mate - All	1600 psi	89.6 bar, 8.9 MPa
145cc Dura-Flow - SS	5600 psi	386 bar, 38.6 MPa
180cc Dura-Flow - SS	4500 psi	310 bar, 31.0 MPa
220cc Dura-Flow - SS	3700 psi	255 bar, 25.5 MPa
290cc Dura-Flow - SS	2800 psi	193 bar, 19.3 MPa
430cc Dura-Flow - SS	1900 psi	131 bar, 13.1 MPa
115cc Dura-Flow - CS	6000 psi	414 bar, 41.4 MPa
145cc Dura-Flow - CS	5600 psi	386 bar, 38.6 MPa
180cc Dura-Flow - CS	4500 psi	319 bar, 31.0 MPa
220cc Dura-Flow - CS	3700 psi	255 bar, 25.5 MPa
290cc Dura-Flow - CS	2800 psi	193 bar, 19.3 MPa
<b>Fluid outlet size</b>		
Check-Mate 100, 200, 250	1" NPT female	
Check-Mate 500	1-1/2" NPT female	
Dura-Flow 115, 145, 180, 220, 290	1" NPT female	
Dura-Flow 430	1-1/2" NPT female	
<b>Maximum air input pressure (supply system)</b>		
D60 - 3 in. dual post, 5 gal. (20 L)	150 psi	1.0 MPa, 10 bar
D200 - 3 in. dual post, 55 gal. (200 L)	150 psi	1.0 MPa, 10 bar
D200s - 6.5 in. dual post, 55 gal. (200 L)	125 psi	0.9 MPa, 9 bar

<b>E-Flo SP Supply Systems</b>		
	<b>US</b>	<b>Metric</b>
<b>Platen wetted materials</b>		
257727, 5 gal. (20 L)	Electroless nickel, polyurethane, nitrile, carbon steel, polyethylene, zinc plated carbon steel, buna, 316 sst, 17-4PH sst	
257732, 8 gal. (30 L)		
257737, 16gal. (60 L)		
257728, 5 gal. (20 L)	Electroless nickel, polyurethane, carbon steel, polyethylene, nitrile, zinc plated carbon steel, buna, 316 sst 17-4PH sst	
257733, 8 gal. (30 L)		
257740, 16gal. (60 L)		
257729, 5 gal. (20 L)	Stainless steel, polyurethane, PTFE coated nitrile, polyethylene, nitrile, PTFE, 303 sst, 304 sst, 316 sst, 17-4PH sst	
257734, 8 gal. (30 L)		
257738, 16gal. (60 L)		
257730, 5 gal. (20 L)	Electroless nickel, aramind reinforced elastomer, rubber-based PSA, nitrile, polyethylene, zinc plated carbon steel, buna, 1018 carbon steel, 304 sst, 316 sst, 17-4PH sst	
257735, 8 gal. (30 L)		
257739, 16gal. (60 L)		
257731, 5 gal. (20 L)	Electroless nickel, aramind reinforced elastomer, rubber-based PSA, polyurethane, polyethylene, nitrile, zinc plated carbon steel, buna, 1018 carbon steel, 304 sst, 316 sst, 17-4PH sst	
257736, 8 gal. (30 L)		
257741, 16gal. (60 L)		
25E110, 5 gal. (20 L)	Electroless nickel, nitrile, carbon steel, zinc plated carbon steel, buna, 316 sst, 17-4PH sst, aluminum, PVC	
25A206, 5 gal. (20 L)	Stainless steel, polyurethane, nitrile (FDA approved), polyethylene	

## California Proposition 65

### CALIFORNIA RESIDENTS

 **WARNING:** Cancer and reproductive harm – [www.P65warnings.ca.gov](http://www.P65warnings.ca.gov).

# Graco Standard Warranty

Graco warrants all equipment referenced in this document which is manufactured by Graco and bearing its name to be free from defects in material and workmanship on the date of sale to the original purchaser for use. With the exception of any special, extended, or limited warranty published by Graco, Graco will, for a period of twelve months from the date of sale, repair or replace any part of the equipment determined by Graco to be defective. This warranty applies only when the equipment is installed, operated and maintained in accordance with Graco's written recommendations.

This warranty does not cover, and Graco shall not be liable for general wear and tear, or any malfunction, damage or wear caused by faulty installation, misapplication, abrasion, corrosion, inadequate or improper maintenance, negligence, accident, tampering, or substitution of non-Graco component parts. Nor shall Graco be liable for malfunction, damage or wear caused by the incompatibility of Graco equipment with structures, accessories, equipment or materials not supplied by Graco, or the improper design, manufacture, installation, operation or maintenance of structures, accessories, equipment or materials not supplied by Graco.

This warranty is conditioned upon the prepaid return of the equipment claimed to be defective to an authorized Graco distributor for verification of the claimed defect. If the claimed defect is verified, Graco will repair or replace free of charge any defective parts. The equipment will be returned to the original purchaser transportation prepaid. If inspection of the equipment does not disclose any defect in material or workmanship, repairs will be made at a reasonable charge, which charges may include the costs of parts, labor, and transportation.

**THIS WARRANTY IS EXCLUSIVE, AND IS IN LIEU OF ANY OTHER WARRANTIES, EXPRESS OR IMPLIED, INCLUDING BUT NOT LIMITED TO WARRANTY OF MERCHANTABILITY OR WARRANTY OF FITNESS FOR A PARTICULAR PURPOSE.**

Graco's sole obligation and buyer's sole remedy for any breach of warranty shall be as set forth above. The buyer agrees that no other remedy (including, but not limited to, incidental or consequential damages for lost profits, lost sales, injury to person or property, or any other incidental or consequential loss) shall be available. Any action for breach of warranty must be brought within two (2) years of the date of sale.

**GRACO MAKES NO WARRANTY, AND DISCLAIMS ALL IMPLIED WARRANTIES OF MERCHANTABILITY AND FITNESS FOR A PARTICULAR PURPOSE, IN CONNECTION WITH ACCESSORIES, EQUIPMENT, MATERIALS OR COMPONENTS SOLD BUT NOT MANUFACTURED BY GRACO.** These items sold, but not manufactured by Graco (such as electric motors, switches, hose, etc.), are subject to the warranty, if any, of their manufacturer. Graco will provide purchaser with reasonable assistance in making any claim for breach of these warranties.

In no event will Graco be liable for indirect, incidental, special or consequential damages resulting from Graco supplying equipment hereunder, or the furnishing, performance, or use of any products or other goods sold hereto, whether due to a breach of contract, breach of warranty, the negligence of Graco, or otherwise.

## **FOR GRACO CANADA CUSTOMERS**

The Parties acknowledge that they have required that the present document, as well as all documents, notices and legal proceedings entered into, given or instituted pursuant hereto or relating directly or indirectly hereto, be drawn up in English. Les parties reconnaissent avoir convenu que la rédaction du présente document sera en Anglais, ainsi que tous documents, avis et procédures judiciaires exécutés, donnés ou intentés, à la suite de ou en rapport, directement ou indirectement, avec les procédures concernées.

# Graco Information

## Sealant and Adhesive Dispensing Equipment

For the latest information about Graco products, visit [www.graco.com](http://www.graco.com).

For patent information, see [www.graco.com/patents](http://www.graco.com/patents).

**TO PLACE AN ORDER**, contact your Graco distributor, go to [www.graco.com](http://www.graco.com), or call to identify the nearest distributor.

**If calling from the USA:** 1-800-746-1334

**If calling from outside the USA:** 0-1-330-966-3000

*All written and visual data contained in this document reflects the latest product information available at the time of publication. Graco reserves the right to make changes at any time without notice.*

Original instructions. This manual contains English. MM 3A6331

**Graco Headquarters:** Minneapolis

**International Offices:** Belgium, China, Japan, Korea

**GRACO INC. AND SUBSIDIARIES • P.O. BOX 1441 • MINNEAPOLIS MN 55440-1441 • USA**  
**Copyright 2018, Graco Inc. All Graco manufacturing locations are registered to ISO 9001.**

[www.graco.com](http://www.graco.com)  
Revision H, August 2021