

Winkelpolierer
Angle polisher
Satineuse

UPG 5-R

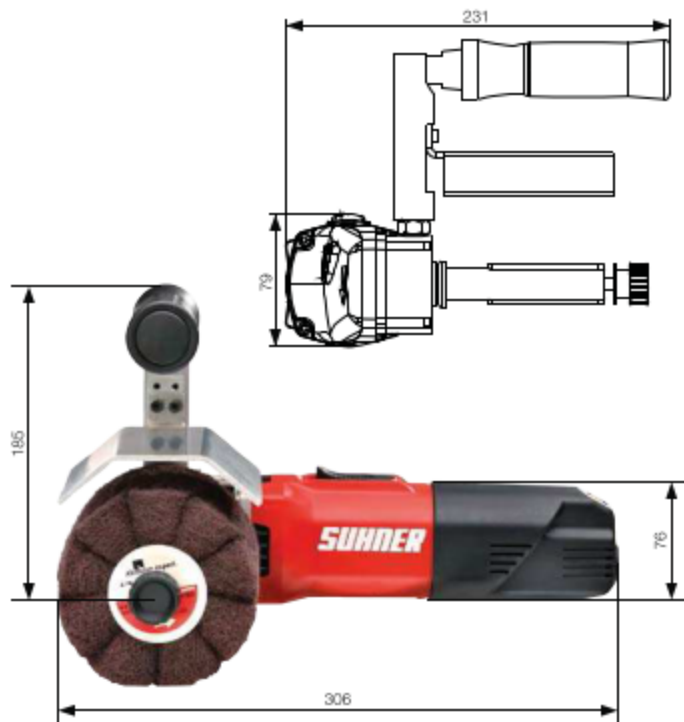

- Working spindle 19 × 100mm to take drum sander and flap brushes can be exchanged to M14
- A selection of drum sander belts as well as flap brushes in A/O, zirconia and non-woven nylon available
- Extremely light
- Increased safety for the user thanks to thermal protection and smooth start
- Digital electronics ensures constant working speed
- Undervoltage protection. Unintentional activation following a voltage interruption, even with the machine on, is impossible
- Outgoing air guided past user at 45°

Applications

Preparing and finishing – buffing/polishing stainless steel, copper, brass, bronze, aluminum, particularly in food & beverage equipment manufacturers shops, chemical & pharmaceutical industries and general metal fabricators.



Technische Daten / Technical data / Caractéristiques techniques

| Typ Type Type | Best.-Nr. Order No. No. de cde. | Drehzahl Speed Vitesse | Spannung Voltage Tension | max. Werkzeug max. wheel Outil max. | Gewicht Weight Poids |
|---------------------|---------------------------------------|------------------------------|--------------------------------|---|----------------------------|
| | | min ⁻¹ | | ø | kg |
| UPG 5-R | 111 234 | 1 800 – 4 000 | 230V/50Hz | 115mm | 2,650 |